

# Art.-Nr. 440 600, 440 610, 440 620

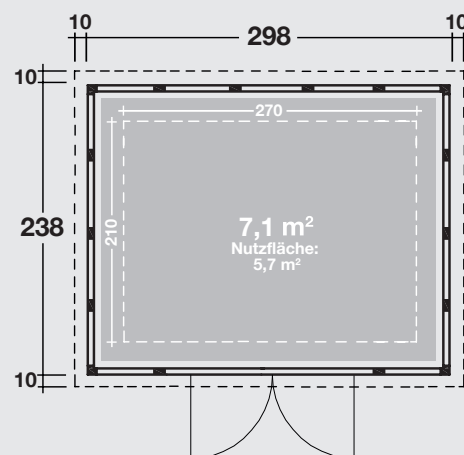

Projet numéro / Project nummer / Project number / Projekt Nummer :

QC-numéro / QC-nummer / QC-number / QC-Nummer :

Couleur / Kleur / Colour / Farbe:



Blanc, Wit, White, Weiß



Gris clair, Licht grijs, Light grey, Lichtgrau



Anthracite, Antraciet, Anthracite, Granitgrau

Zubehör



Fußboden



Innenwand: Innenwandpaket während des Hausaufbaus montieren. Nicht im Nachhinein montierbar!



Lochblech



Bodenschwelle / Rampe

**DONNÉES TECHNIQUES /  
INSTRUCTIONS DE MONTAGE**

**TECHNISCHE GEGEVENS /  
MONTAGE HANDLEIDING**

**TECHNICAL DATA /  
ASSEMBLY INSTRUCTIONS**

**TECHNISCHE DATEN /  
MONTAGEANLEITUNG**



**FINNHAUS**

WOLFF

Nous vous invitons à lire attentivement le présent mode d'emploi.

Vous y trouverez les caractéristiques techniques ainsi que toutes les informations utiles en vue d'un fonctionnement correct. Les données techniques figurant dans cette publication peuvent être modifiées à tout moment et sans avis préalable et ce, pour des raisons techniques ou commerciales..

Wij nodigen u uit deze handleiding aandachtig te lezen.

Ze omvat de technische eigenschappen en alle nuttige informatie voor een correcte werking.

De technische gegevens in deze publicatie kunnen om technische of commerciële redenen op elk moment en zonder voorafgaande kennisgeving worden gewijzigd.

Please read this manual carefully.

It contains the technical properties and all the information required for correct operation.

The technical data in this publication is subject to change for technical and/or commercial reasons at any time and without notice.

Bitte lesen Sie diese Anleitung sorgfältig durch.

Sie enthält die technischen Eigenschaften und alle Informationen, die für einen korrekten Betrieb erforderlich sind.

Die in dieser Publikation enthaltenen technischen Daten können jederzeit ohne Vorankündigung aus technischen oder kommerziellen Gründen geändert werden.



Lisez bien l'ensemble du mode d'emploi avant de commencer à réaliser des travaux.

Lees de volledige handleiding voordat u begint met de werken uit te voeren.

Read the entire manual before you start working.

Lesen Sie vor Arbeitsbeginn die gesamte Anleitung.



L'utilisation de gants est obligatoire.

Het gebruik van handschoenen is verplicht.

The use of gloves is mandatory.

Das Tragen von Handschuhen ist Pflicht.



L'utilisation de lunettes de protection est obligatoire.

Het gebruik van een veiligheidsbril is verplicht.

The use of safety glasses is mandatory.

Das Tragen einer Sicherheitsbrille ist Pflicht.



L'utilisation d'un casque de protection est obligatoire.

Het gebruik van een veiligheidshelm is verplicht.

The use of a hard hat is mandatory.

Das Tragen eines Sicherheitshelms ist Pflicht.

## Liste d'outils / Gereedschappenlijst / Tools List / Werkzeugliste

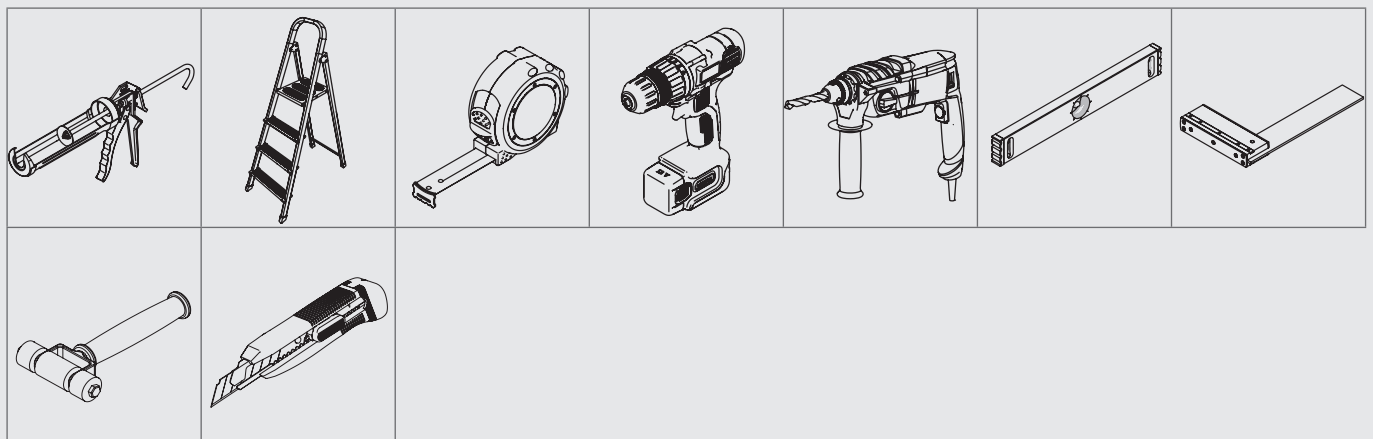

Liste des composants / Stukslijst / Partslist / Teileliste

|                      |                      |                      |                      |   |                      |                      |
|----------------------|----------------------|----------------------|----------------------|---|----------------------|----------------------|
| <b>A21</b> 2x<br>    | <b>A27</b> 1x<br>    | <b>AD27</b> 1x<br>   | <b>B6</b> 21x<br>    | <b>F6</b> 8x<br>                        | <b>HA6</b> 4x<br>    | <b>FD18</b> 1x<br>   |
| <b>UD18</b> 1x<br>   | <b>K6LD</b> 1x<br>   | <b>KT18</b> 1x<br>   | <b>K6R</b> 1x<br>    | <b>K6S</b> 6x<br>                       | <b>DR</b> 1x<br>     | <b>DL</b> 1x<br>     |
| <b>J27R</b> 1x<br>   | <b>J21</b> 2x<br>    | <b>J27</b> 1x<br>    | <b>J21S</b> 2x<br>   | <b>JDA27</b> 1x<br>                     | <b>JD27</b> 1x<br>   | <b>Z27A</b> 1x<br>   |
| <b>Z21B</b> 1x<br>   | <b>Z27C1</b> 1x<br>  | <b>Z27C2</b> 1x<br>  | <b>Z21D</b> 1x<br>   | <b>AB-5</b> 3x<br><b>AB-1,25</b> 1x<br> | <b>3024-1</b> 1x<br> | <b>3024-2</b> 1x<br> |
| <b>3024-3</b> 1x<br> | <b>DA045</b> 12x<br> | <b>DA21</b> 10x<br>  | <b>DA27</b> 6x<br>   | <b>DAVL21</b> 1x<br>                    | <b>DAVR21</b> 1x<br> | <b>DI045</b> 12x<br> |
| <b>DI21</b> 10x<br>  | <b>DI27</b> 6x<br>   | <b>DIVR21</b> 1x<br> | <b>DIVL21</b> 1x<br> | <b>X27A</b> 1x<br>                      | <b>X21B</b> 1x<br>   | <b>X27C</b> 1x<br>   |
| <b>X21D</b> 1x<br>   | <b>IG</b> 2x<br>     | <b>IK</b> 2x<br>     | <b>TP3024</b> 4x<br> | <b>OS18</b> 1x<br>                      | <b>BF21</b> 9x<br>   | <b>PP21</b> 1x<br>   |

option / optie / option / Option



**FINNHAUS**  
WOLFF

Liste des composants / Stukslijst / Partslist / Teileliste

|                   |                    |                     |                     |                         |   |                      |
|-------------------|--------------------|---------------------|---------------------|-------------------------|---|----------------------|
| <b>DK</b> 1x<br>  | <b>CP05</b> 8x<br> | <b>CP01</b> 4x<br>  | <b>CP02</b> 4x<br>  | <b>SD18</b> 2x 200x<br> | <b>SD18BL</b> 30x<br>                               | <b>SD16D</b> 18x<br> |
| <b>BZ</b> 12x<br> | <b>SD25</b> 2x<br> | <b>TOOL1</b> 1x<br> | <b>TOOL2</b> 1x<br> | <b>TOOL3</b> 1x<br>     | <b>RK1</b> 1x<br><b>RK2</b> 1x<br><b>RK3</b> 1x<br> | <b>W1</b> 1x<br>     |
| <b>W2</b> 1x<br>  | <b>W3</b> 1x<br>   | <b>W4</b> 2x<br>    | <b>M27</b> 2x<br>   | <b>M21</b> 2x<br>       |   |                      |

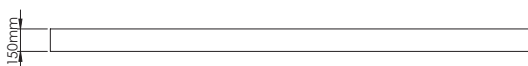
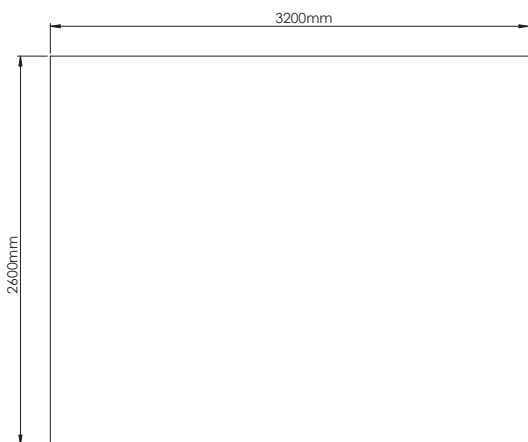

**Fundament**

- Le sol doit être plat et de niveau. Le sol doit être réalisé pour permettre une fixation adéquate de l'abris de jardin.
- De vloer moet vlak en waterpas zijn. De vloer moet gemaakt worden zodat de bevestiging van het tuinhuis wel mogelijk is.
- The floor must be flat and level. The floor must be made in such a way that it is possible to fix the garden house.
- Der Aufbauort muss eine flache, geschlossene und in Waage liegende Bodenplatte aufzeigen. Die Bodenplatte muss so beschaffen sein, das eine mechanische Befestigung von dem Haus erfolgen kann.

**PS**

- L'abris de jardin doit être centrée sur la dalle de béton.
- Het tuinhuis moet gecentreerd geplaatst worden op het fundament.
- The garden house must be centered on the foundation.
- Das Gartenhaus muss auf dem Fundament zentriert sein.

Tous les éléments / Alle elementen / All elements / Alle Elemente

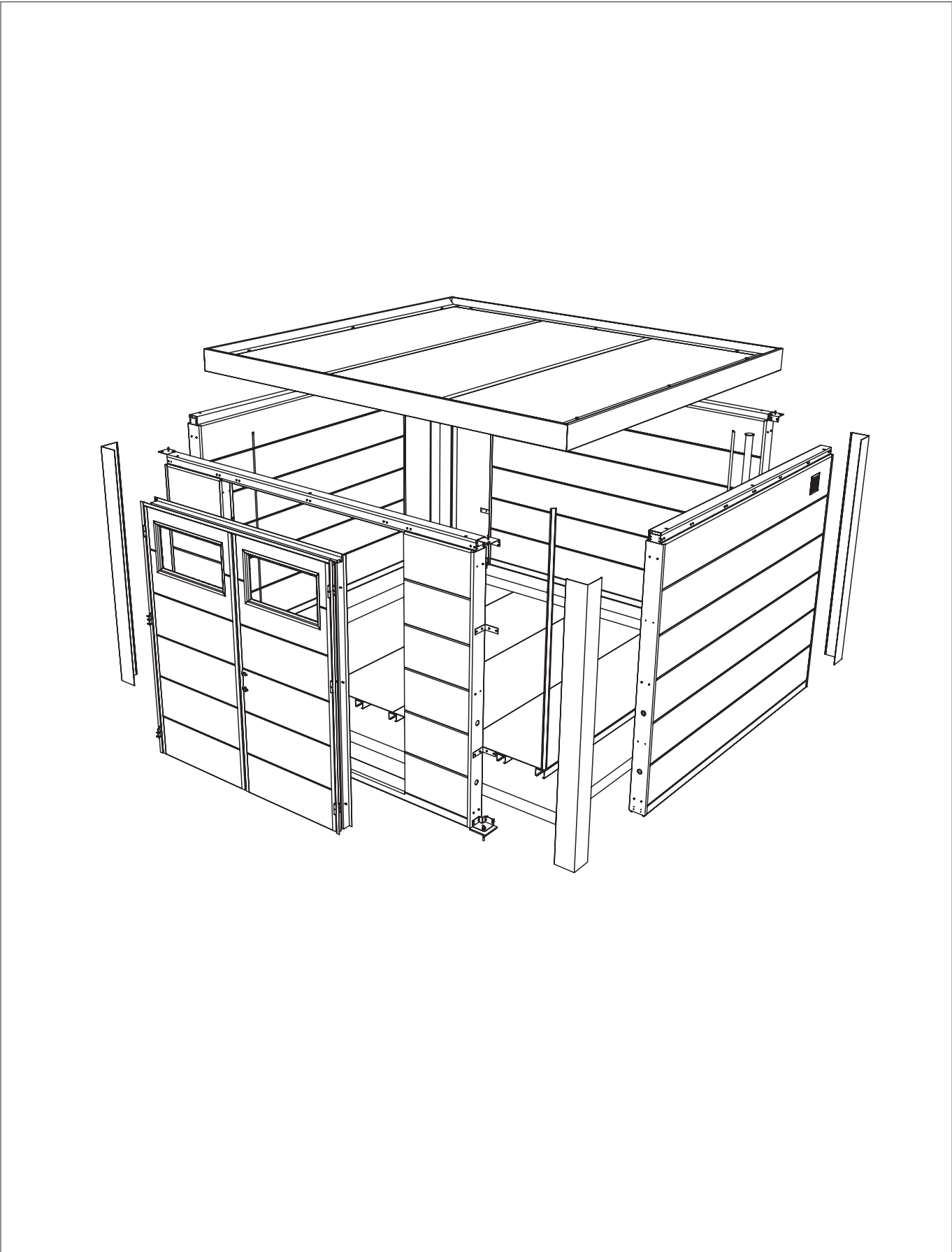

Composition / Compositie / Composition / Zusammensetzung

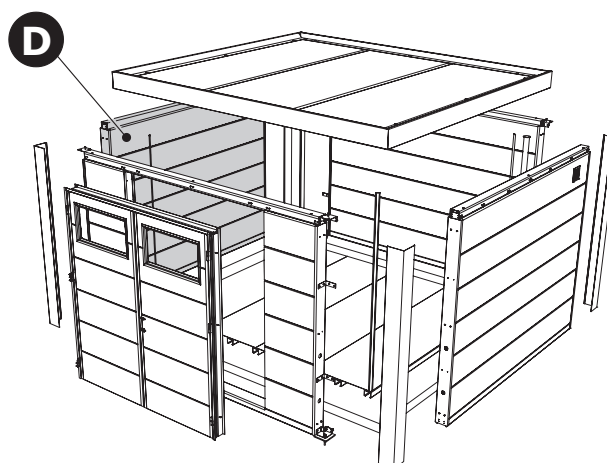
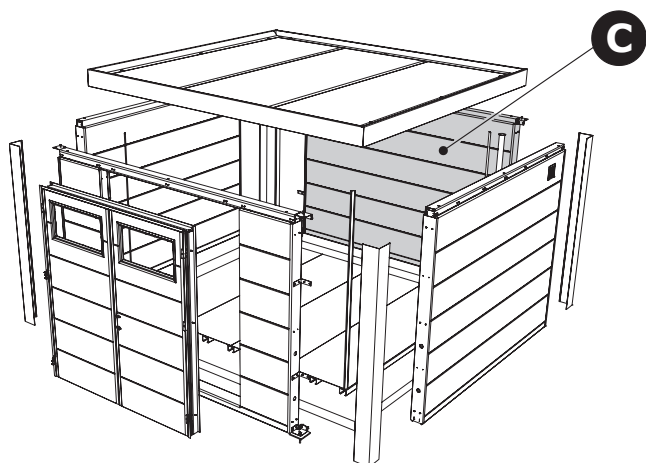
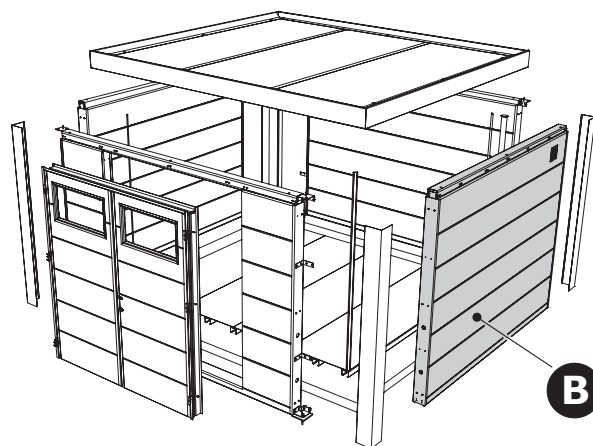
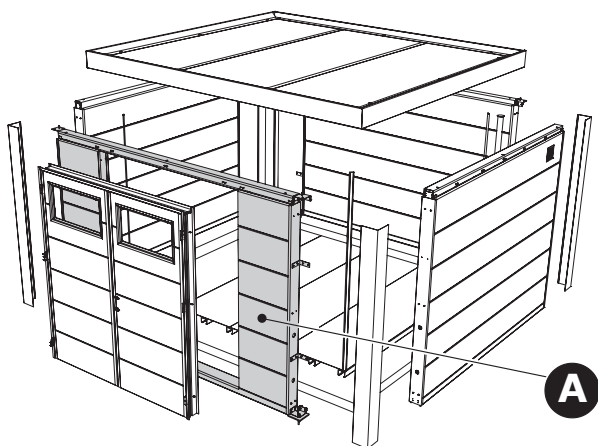
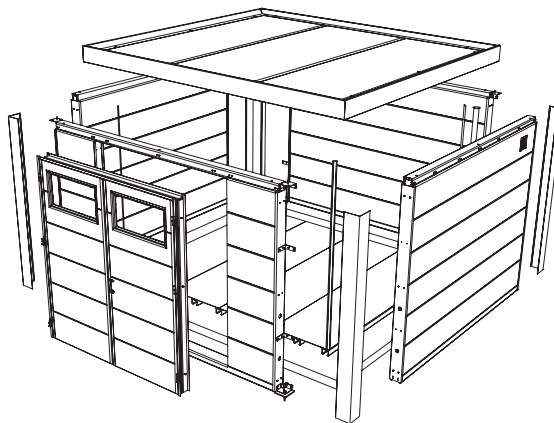
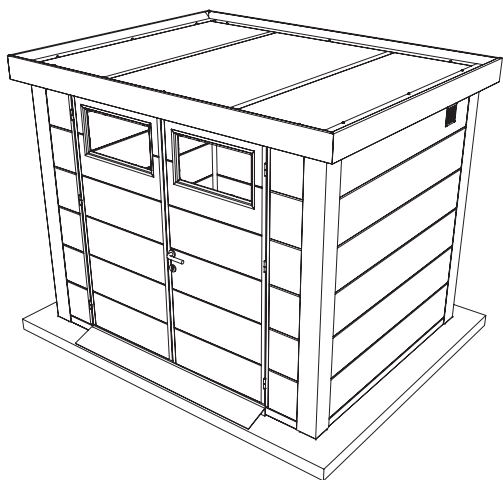

**A**

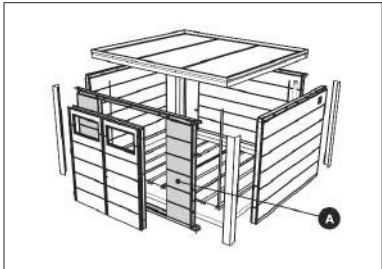
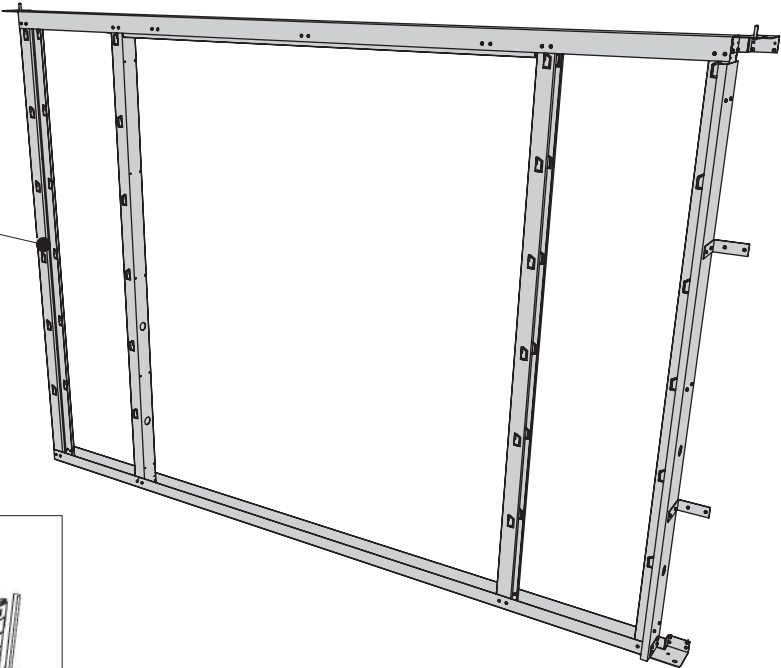

**A** Paroi / Wand / Wall / Wand

**4X B6**

**JD27**

**J27R**

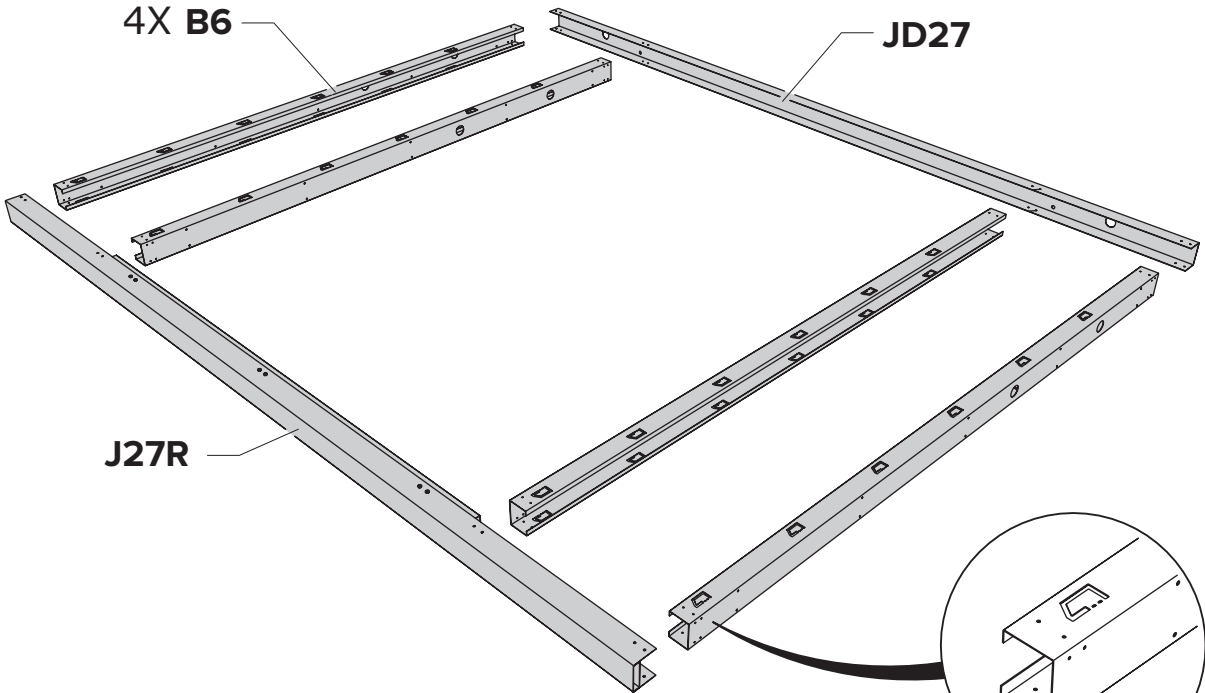

**A** Paroi / Wand / Wall / Wand

Le principe de la construction du mur (POW).  
Het principe van de opbouw van de wand (POW).  
The principle of building the wall (POW).  
Das Prinzip des Baus der Mauer finden (POW).

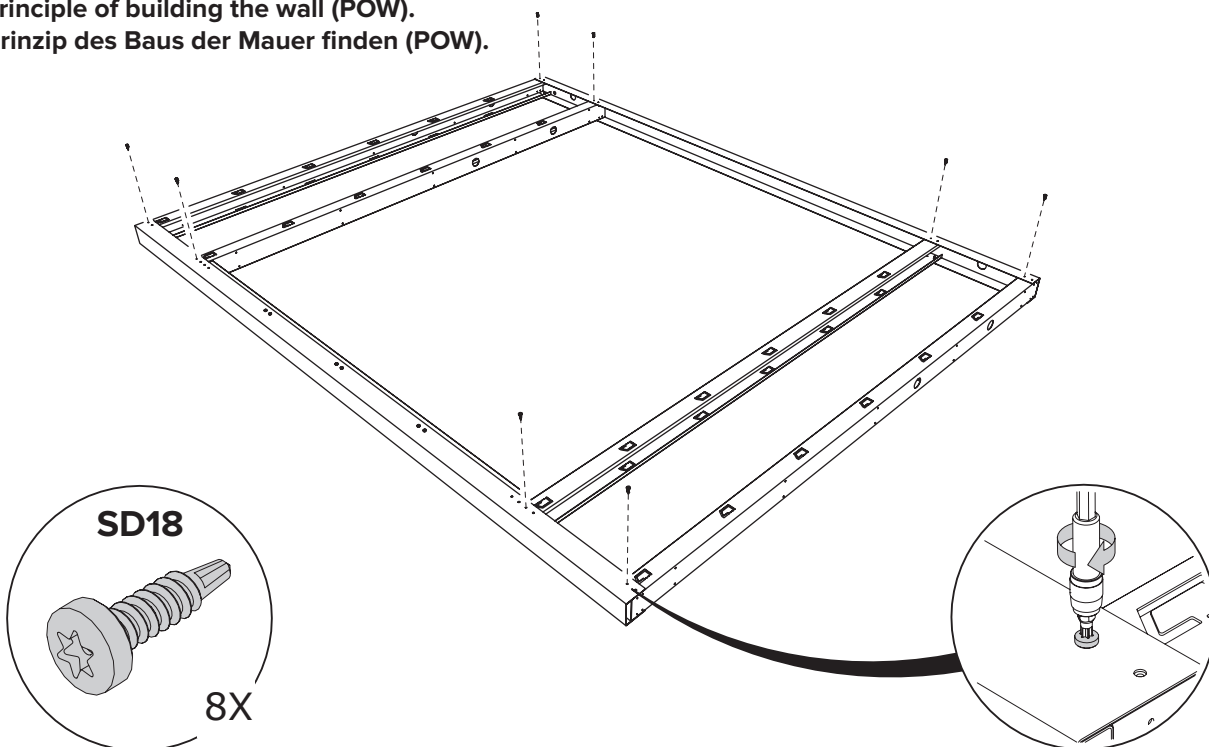

A Paroi / Wand / Wall / Wand

POW

Tourner encadrement / Kader omdraaien / Turn Frame / Rahmen umdrehen

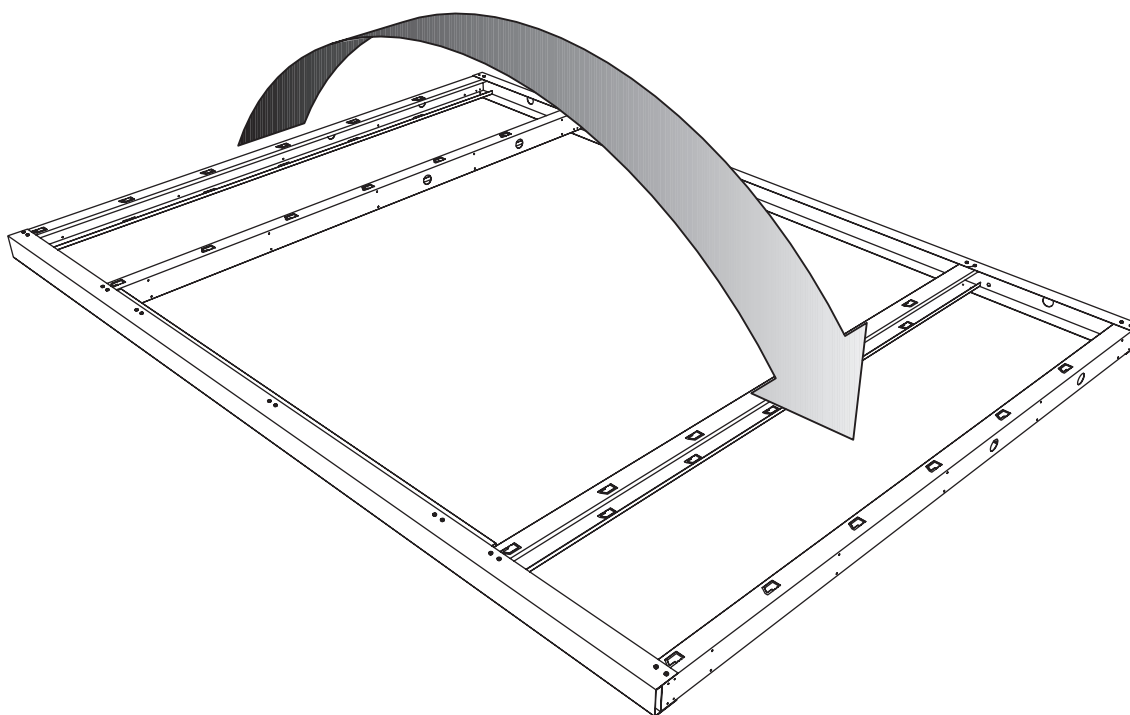

A Paroi / Wand / Wall / Wand

POW



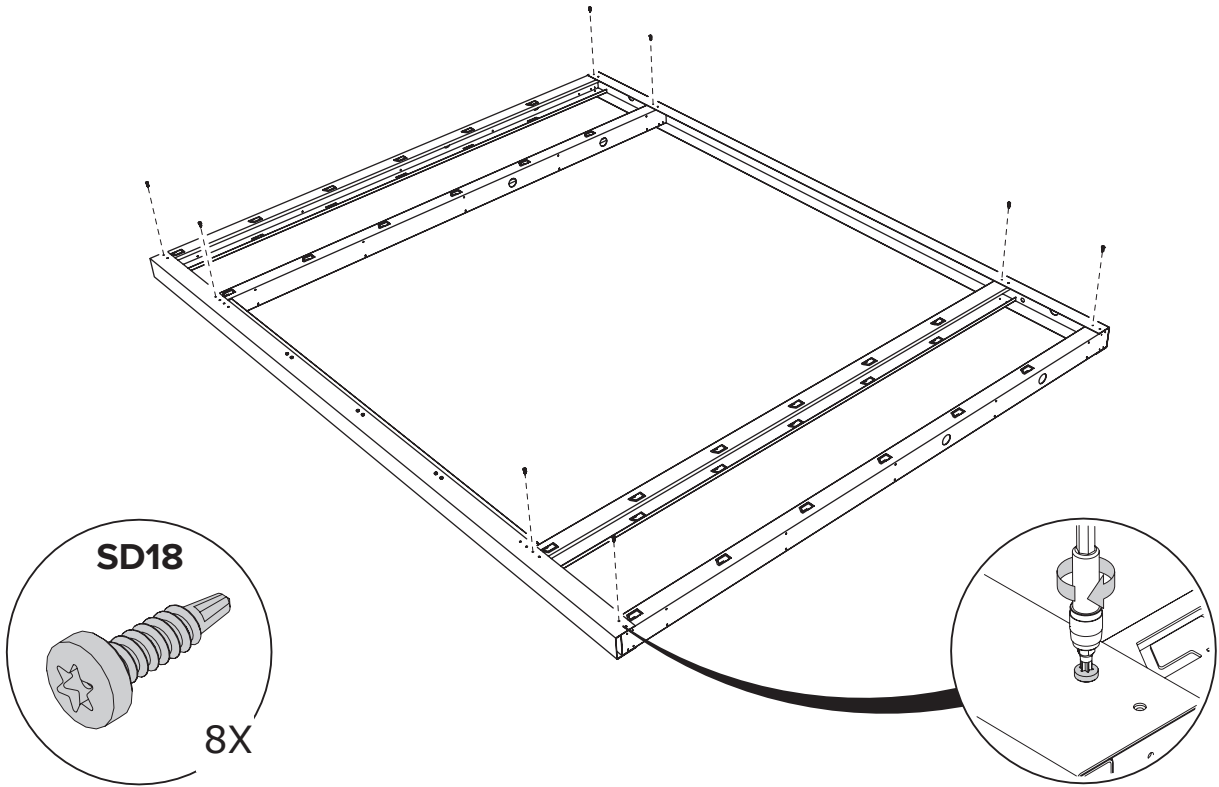

A Paroi / Wand / Wall / Wand

POW

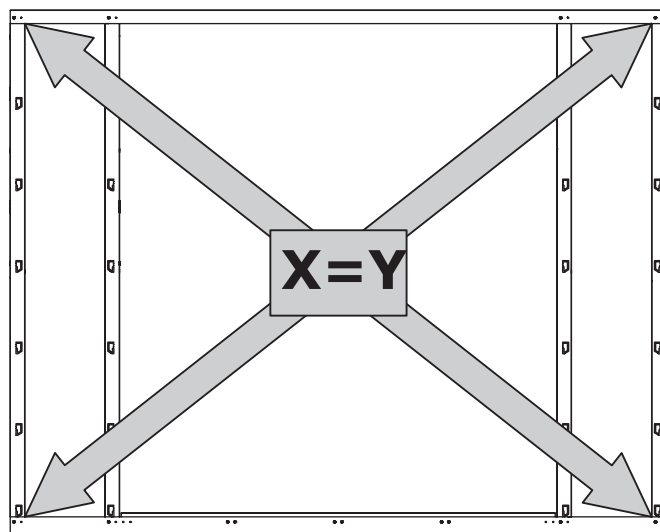
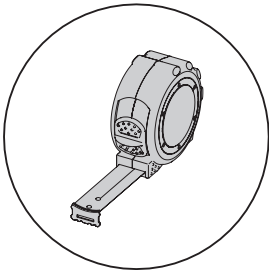

A Paroi / Wand / Wall / Wand

POW

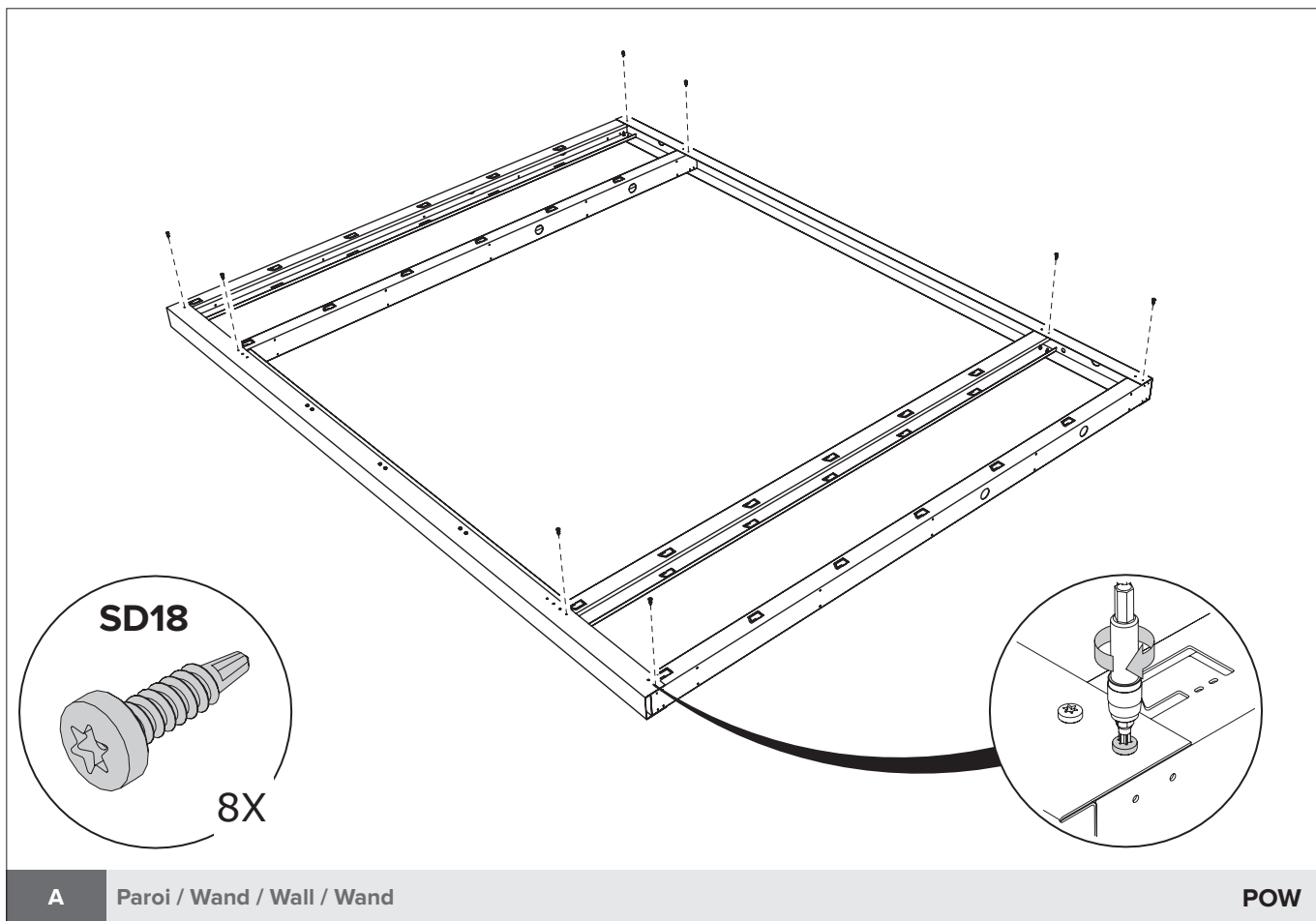

**Tourner encadrement / Kader omdraaien / Turn Frame / Rahmen umdrehen**

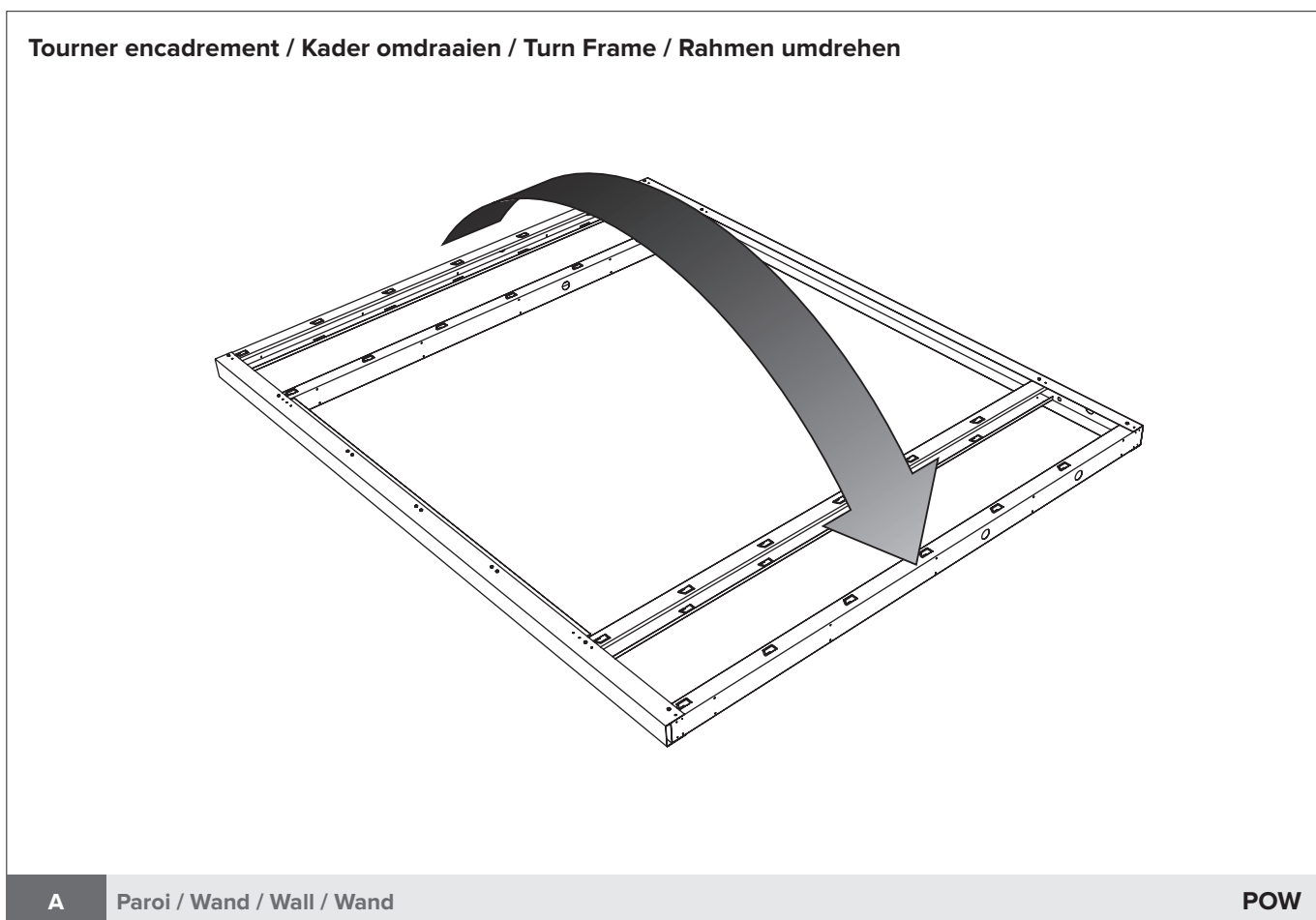

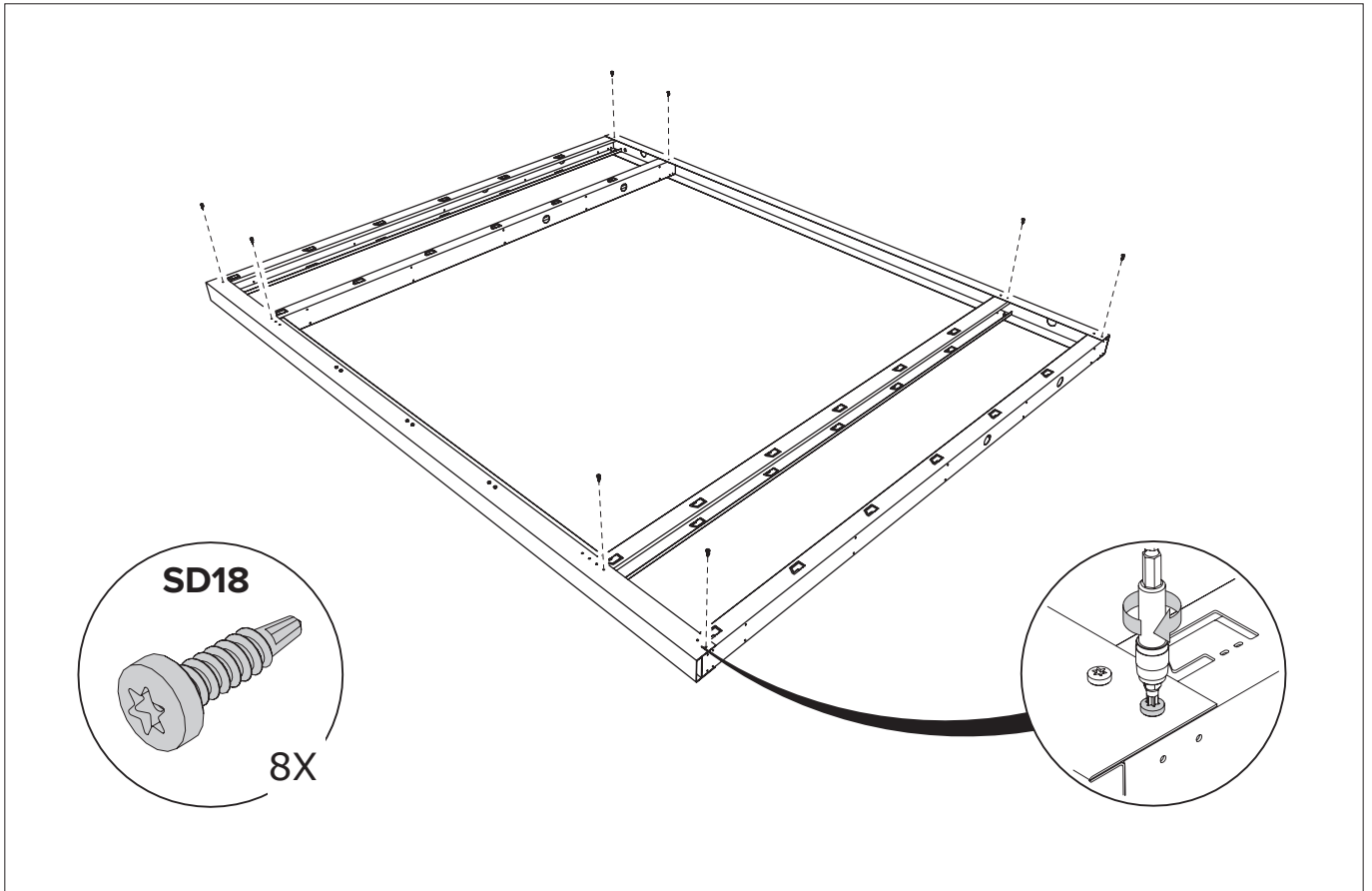

A

Paroi / Wand / Wall / Wand

POW

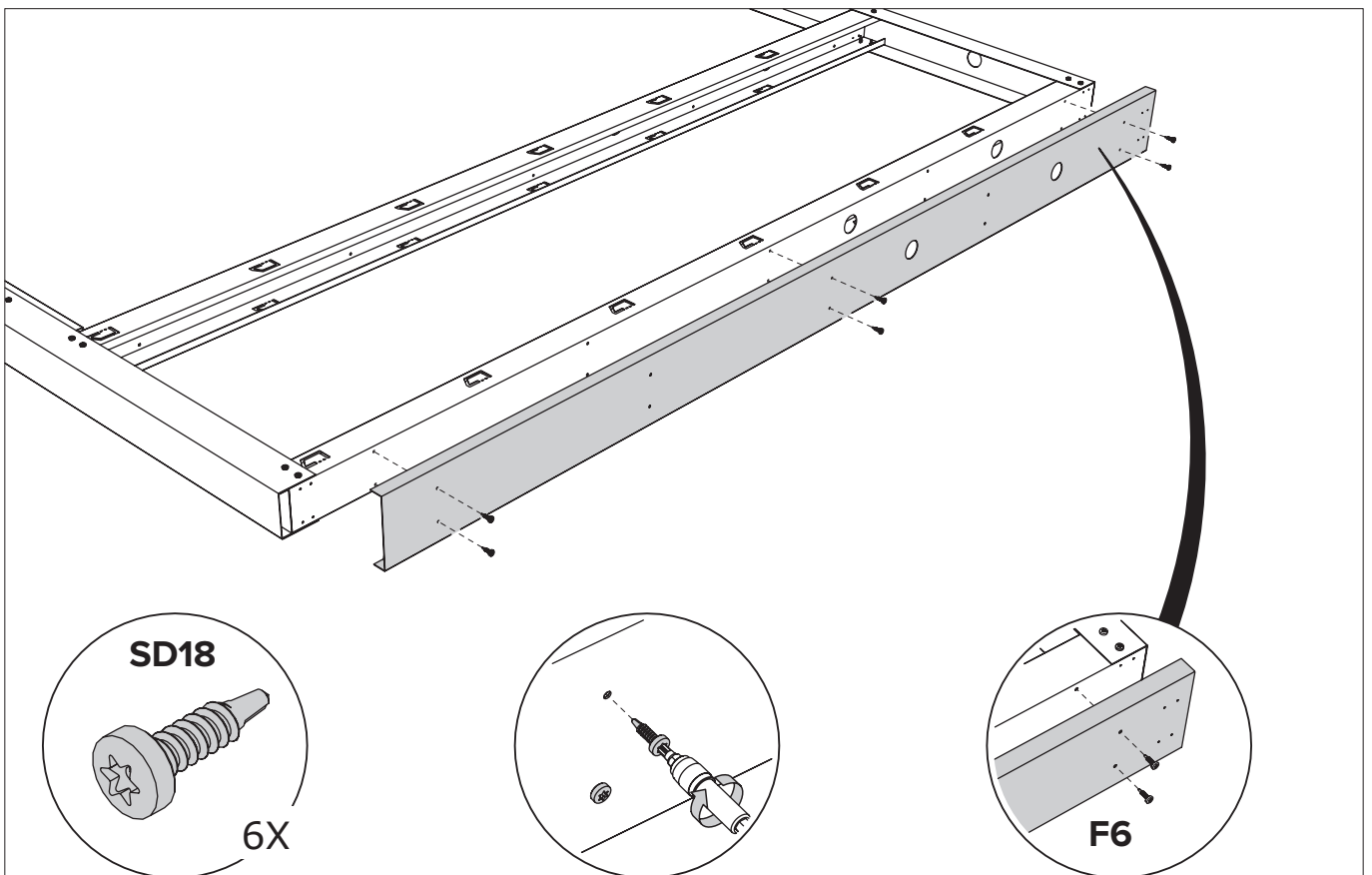

A

Paroi / Wand / Wall / Wand

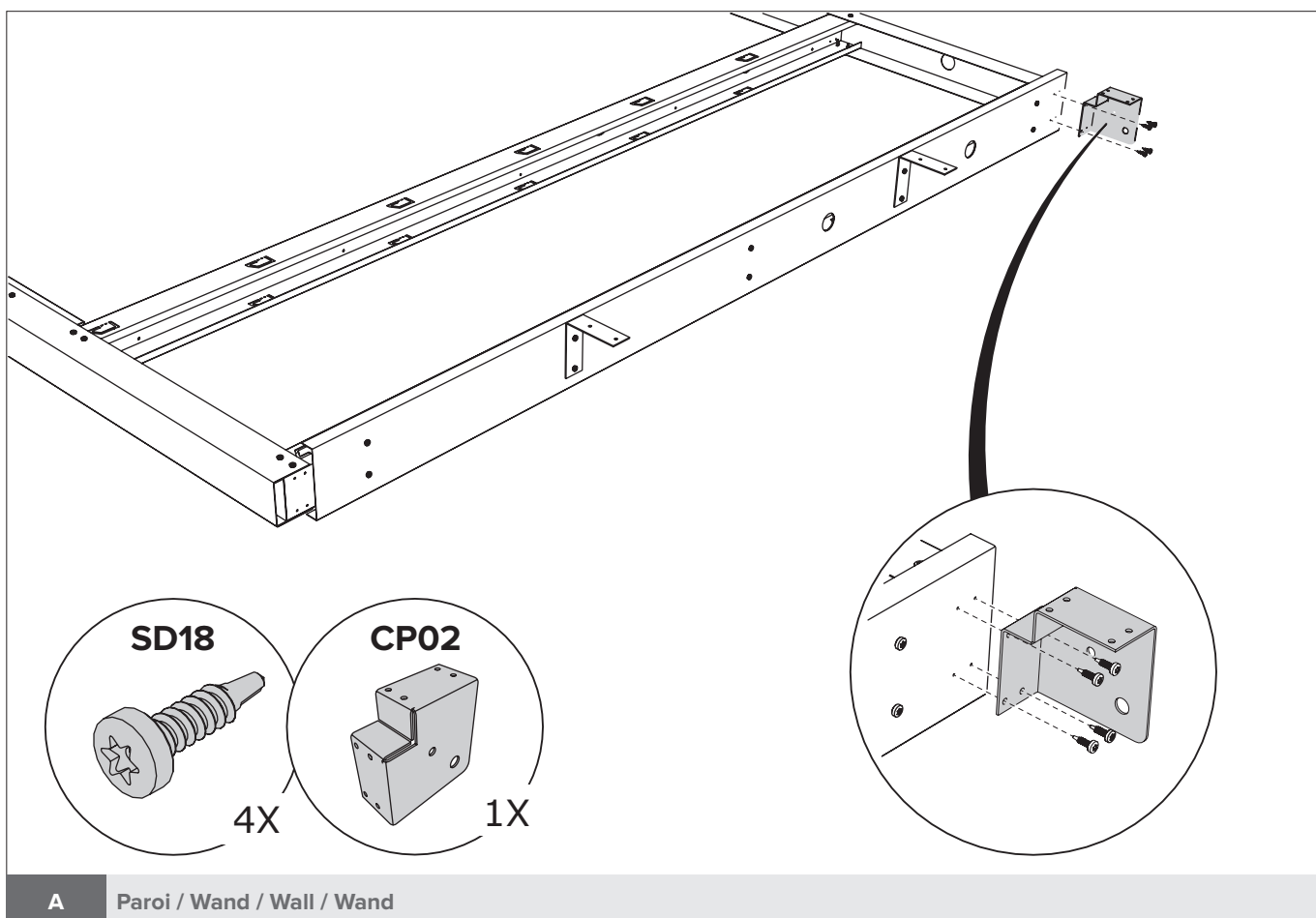
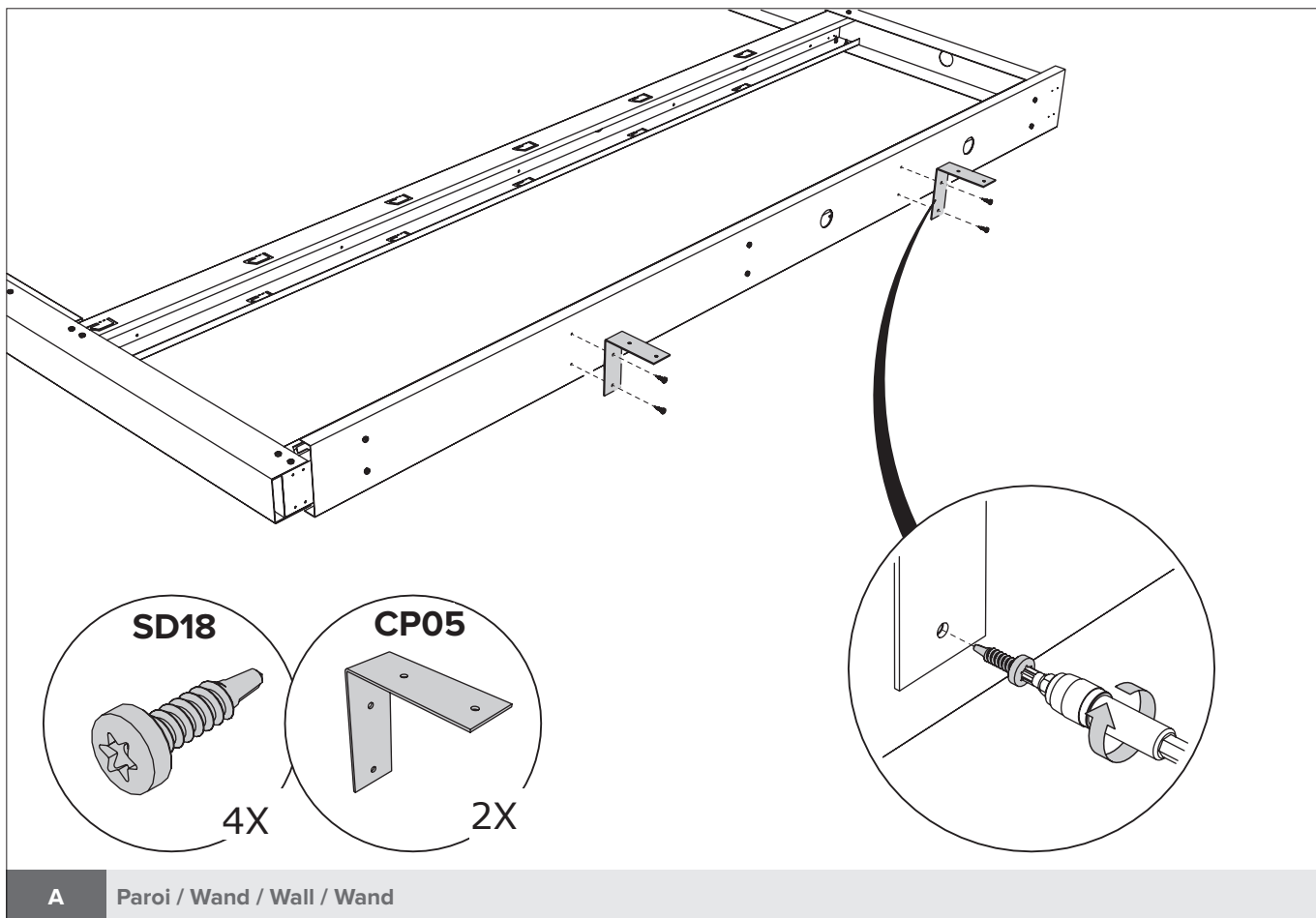

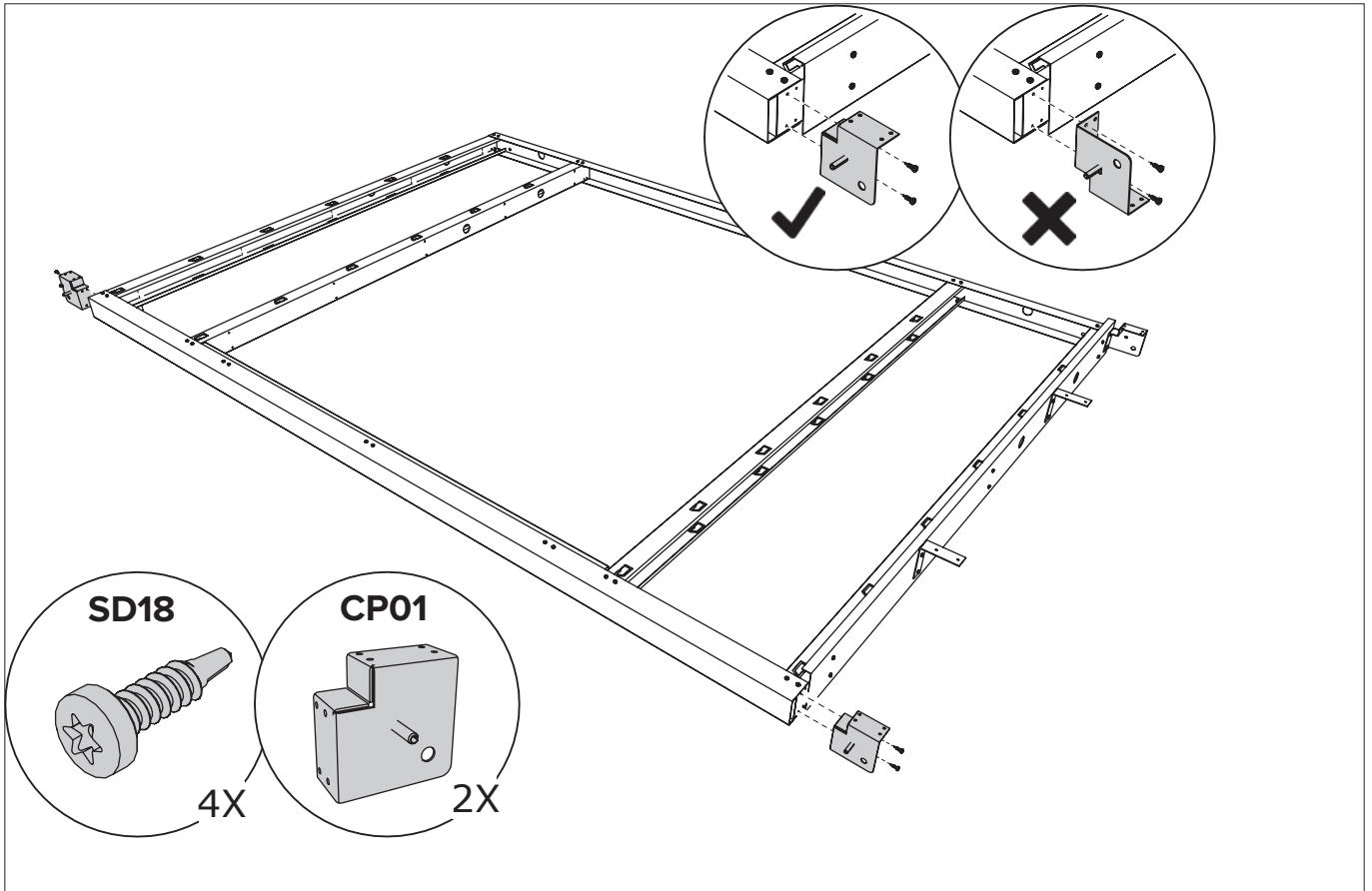

A Paroi / Wand / Wall / Wand

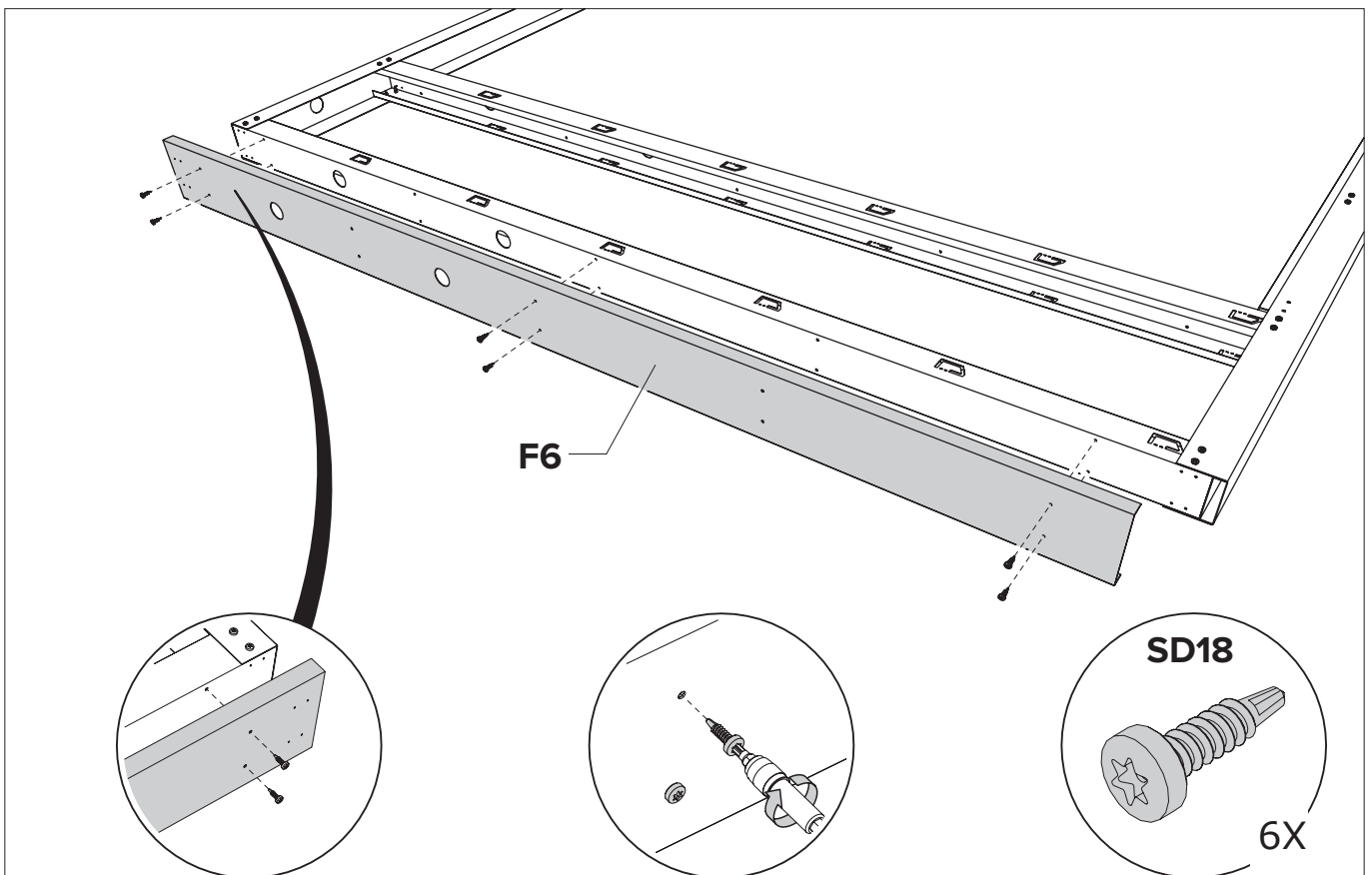

A Paroi / Wand / Wall / Wand

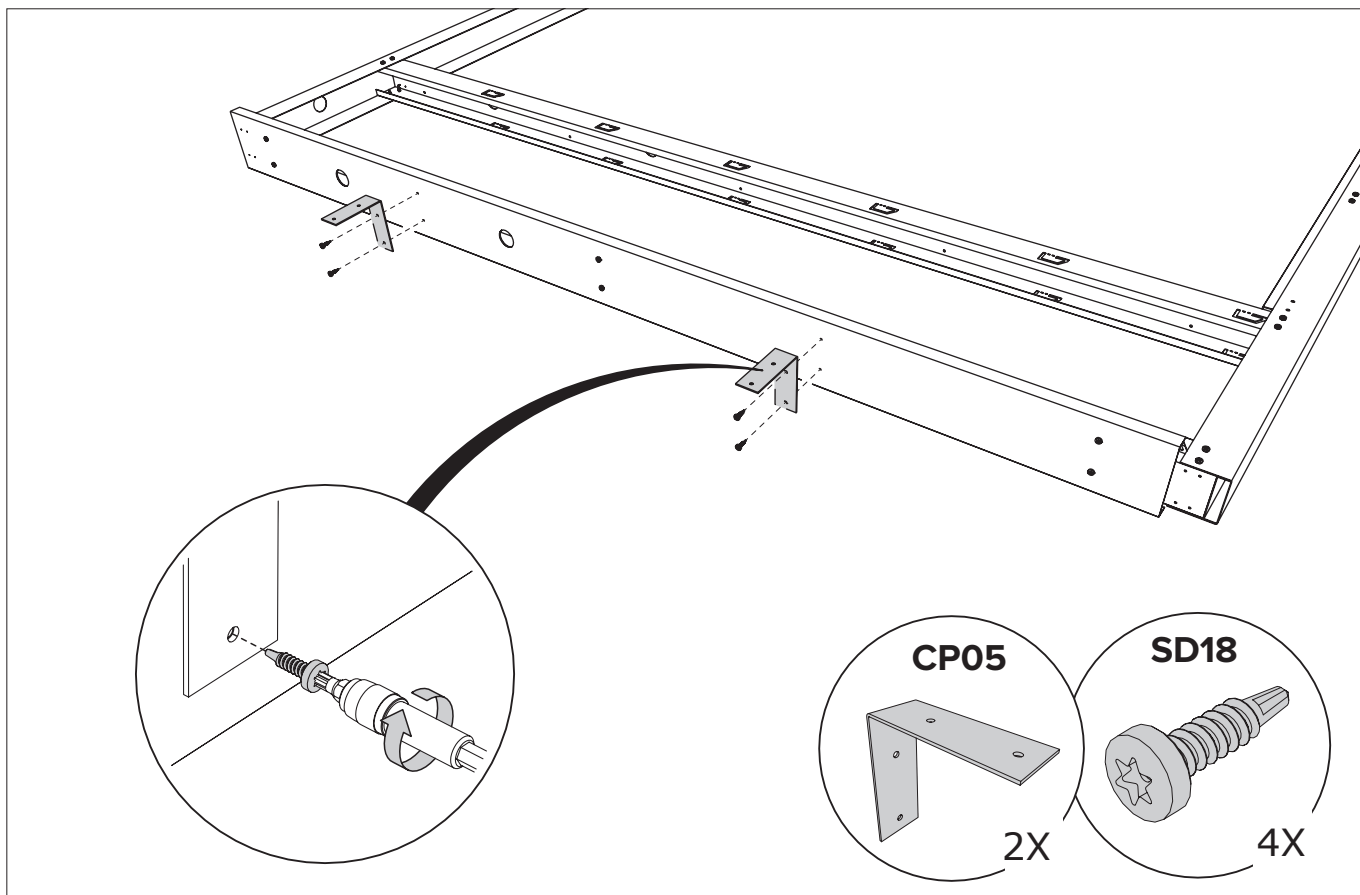

A Paroi / Wand / Wall / Wand

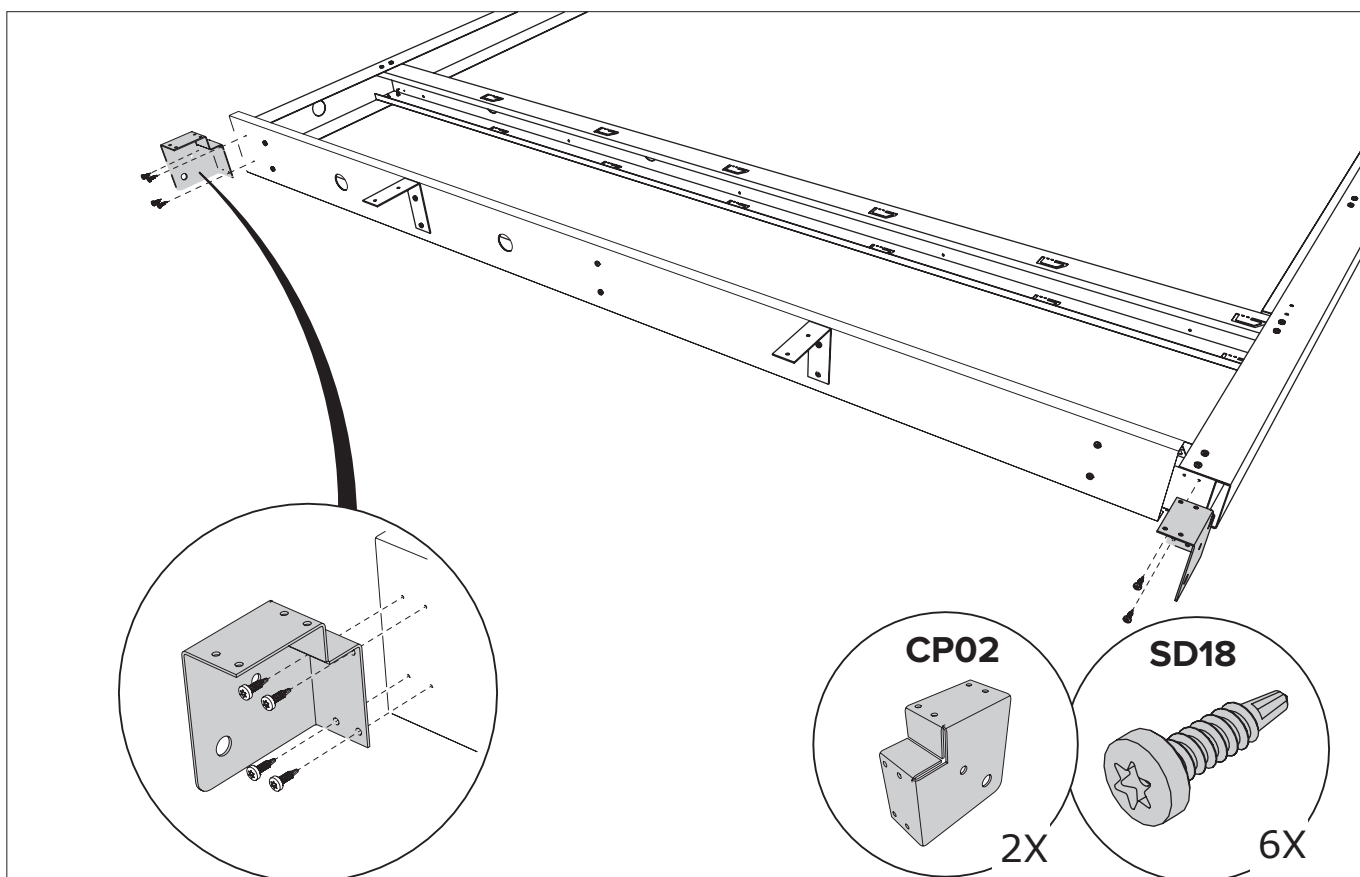

A Paroi / Wand / Wall / Wand

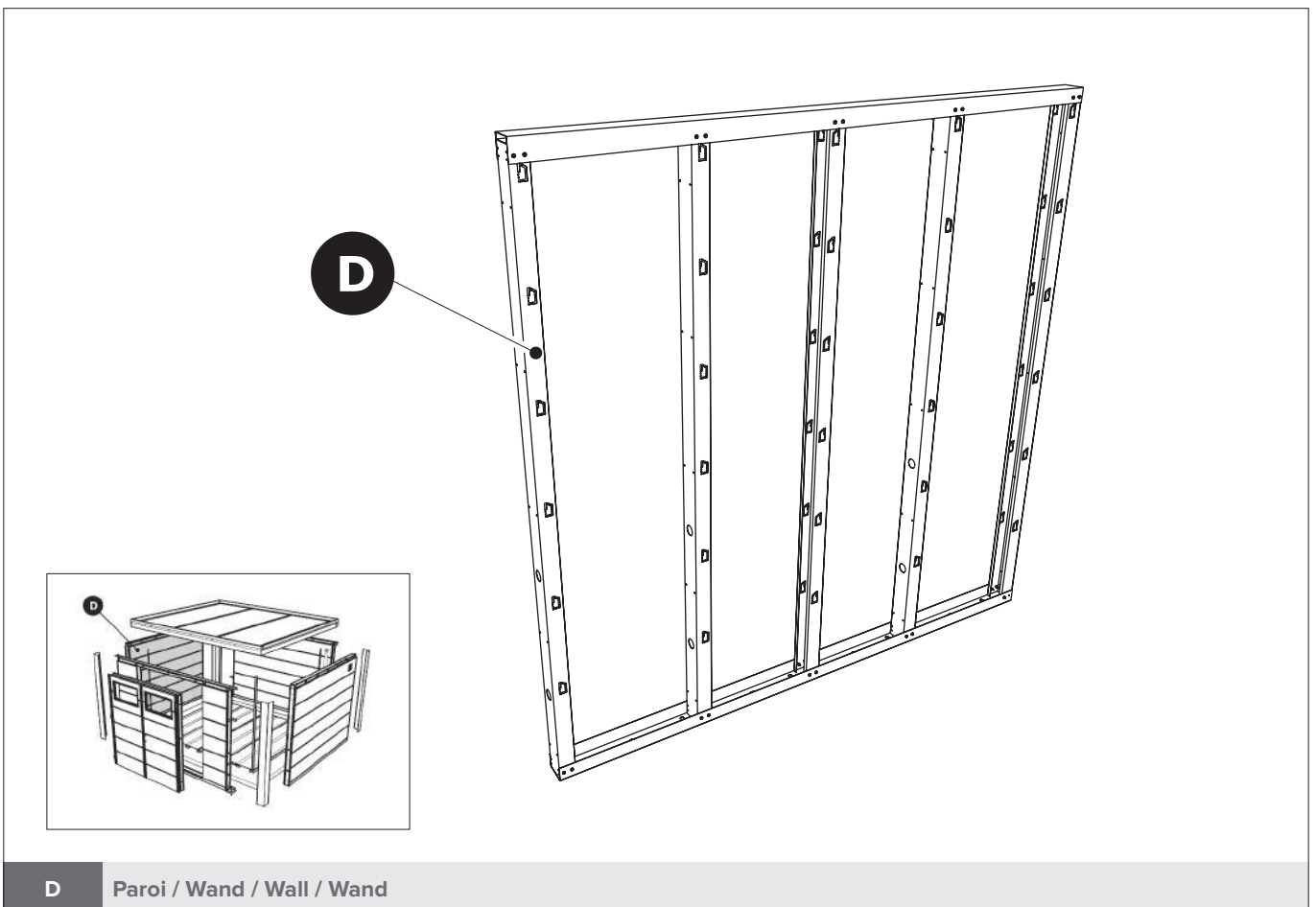
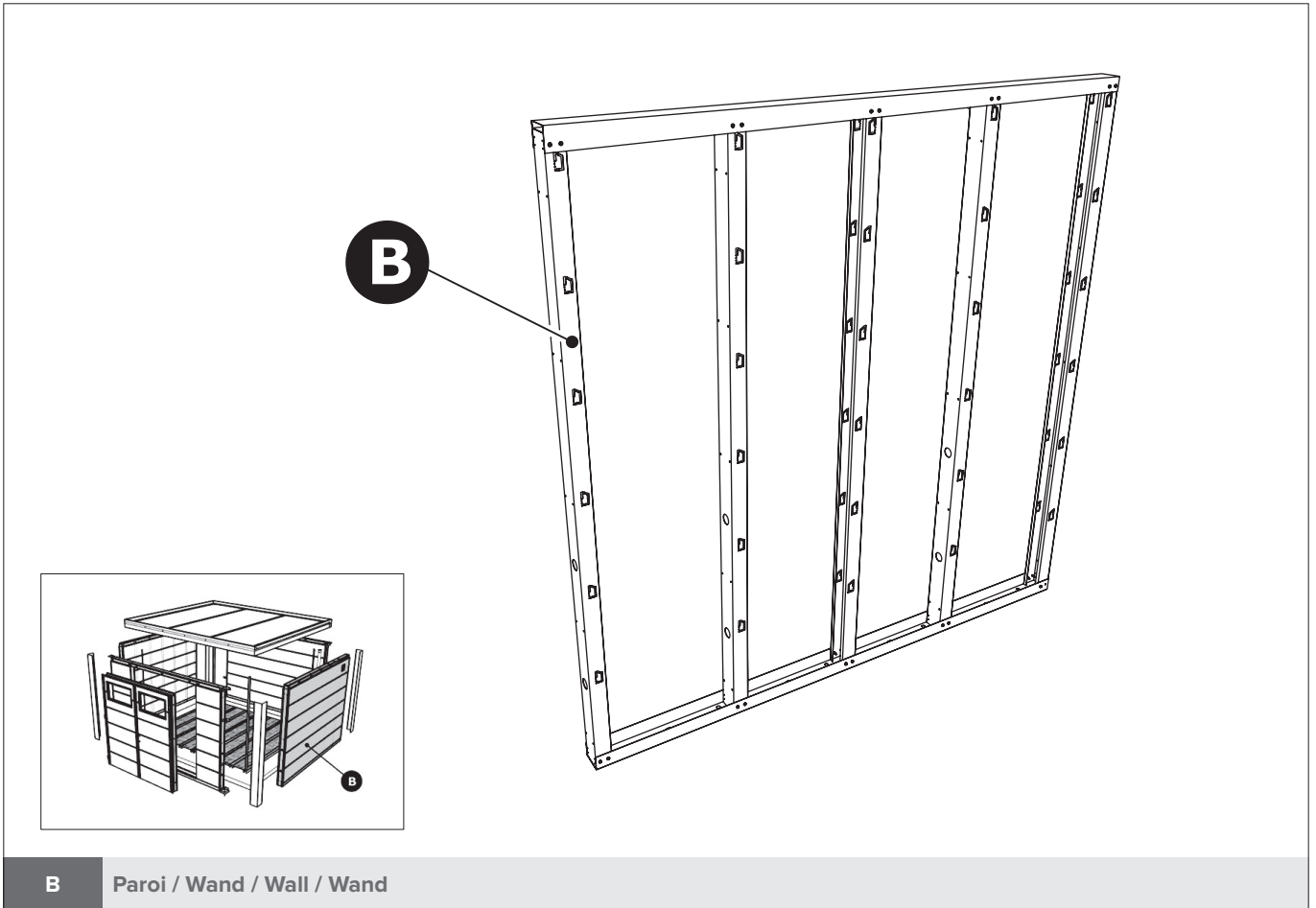

Le principe de la construction du mur, voir pages 8 à 11 (POW).  
 Het principe van de opbouw van de wand, zie pagina 8 tot en met 11 (POW).  
 The principle of building the wall, see pages 8 through 11 (POW).  
 Das Prinzip des Baus der Mauer finden Sie auf den Seiten 8 bis 11 (POW).

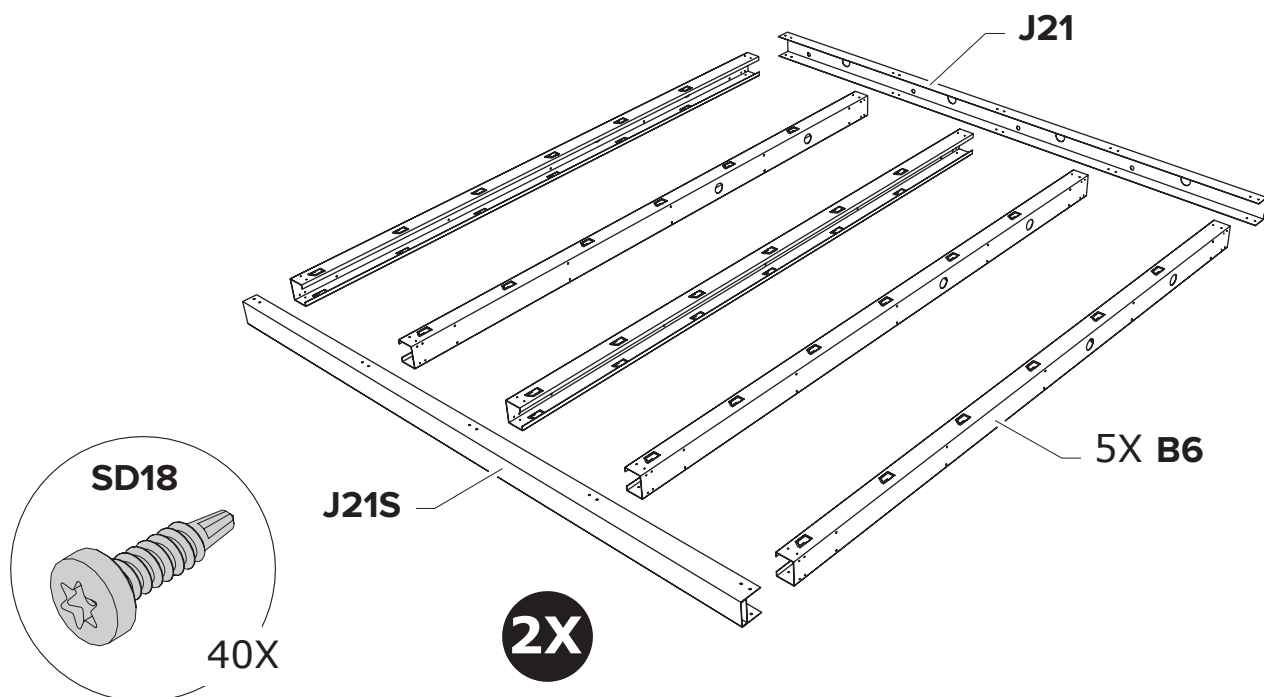

B / D Paroi / Wand / Wall / Wand

**B**

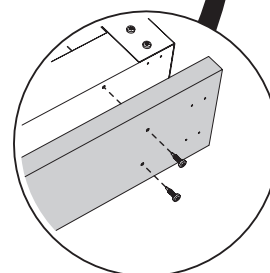
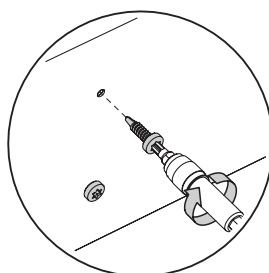
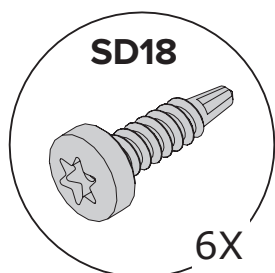
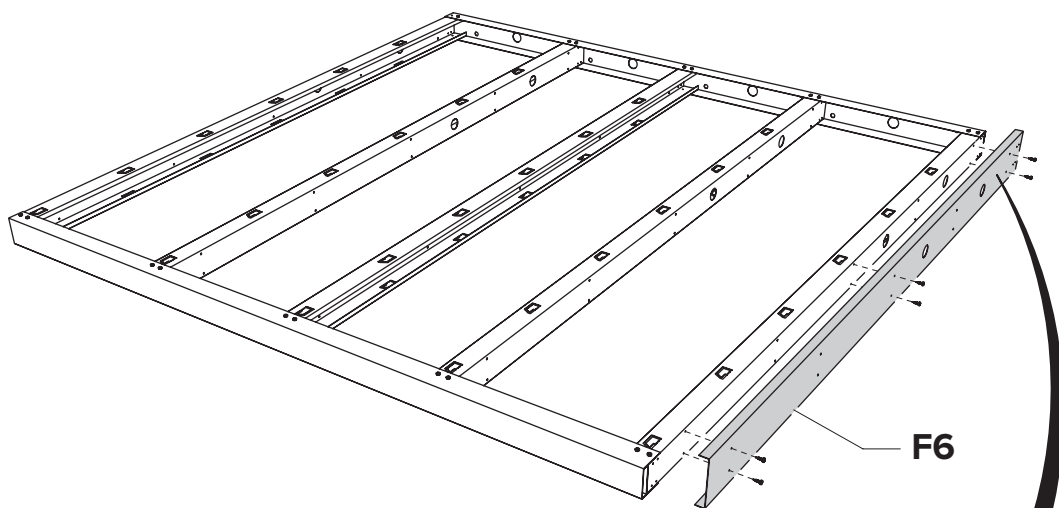

B Paroi / Wand / Wall / Wand



**D**

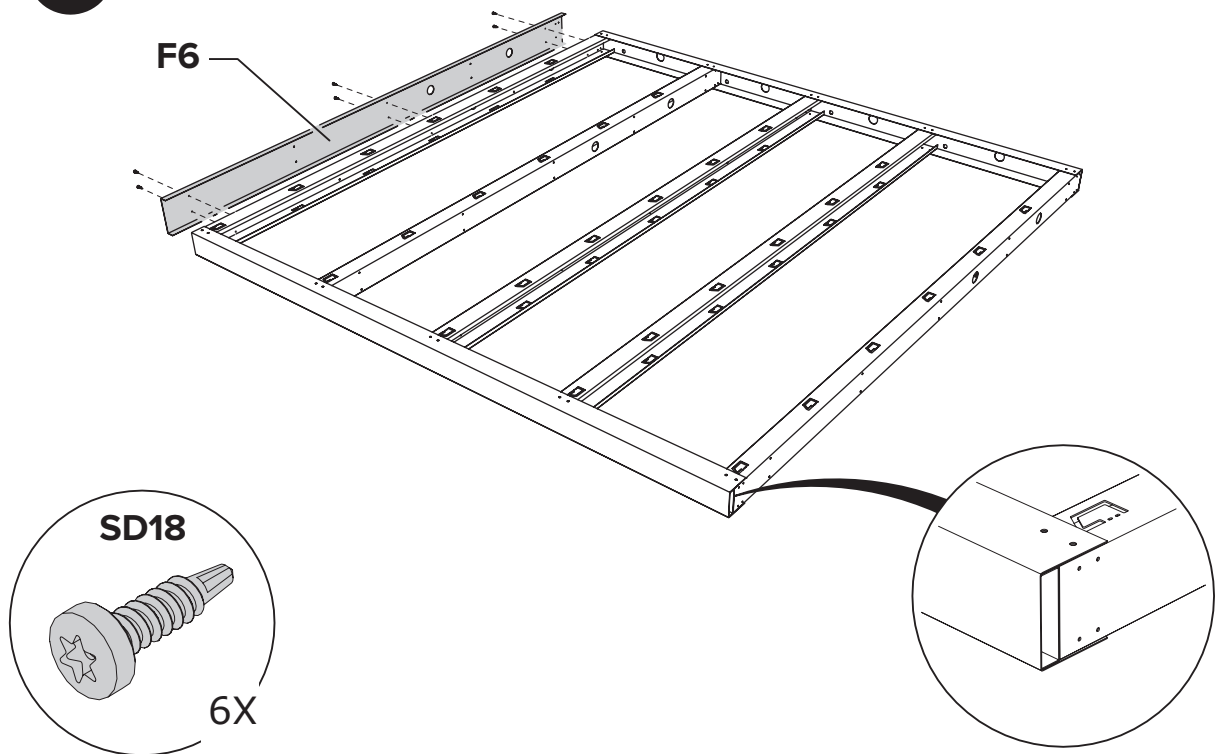

**D** Paroi / Wand / Wall / Wand

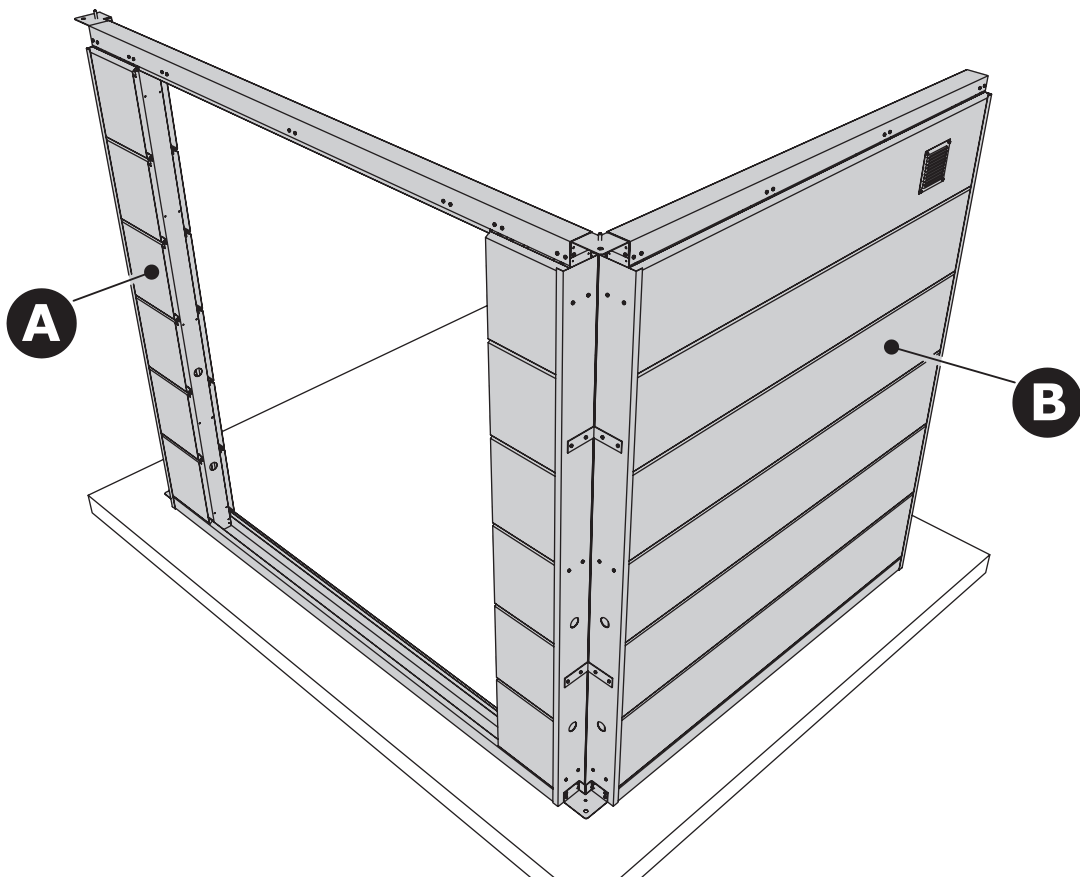

**A + B** Paroi / Wand / Wall / Wand

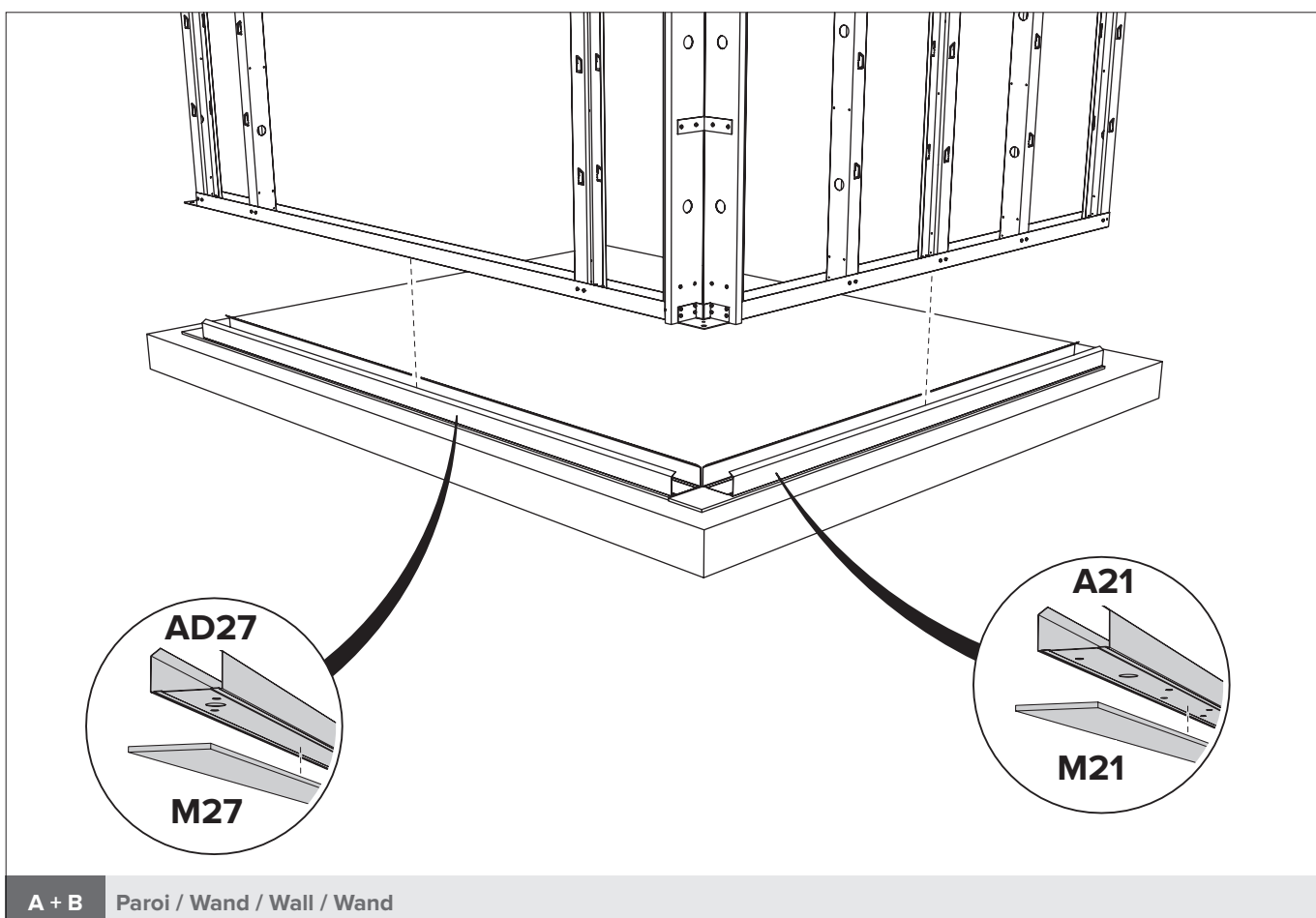
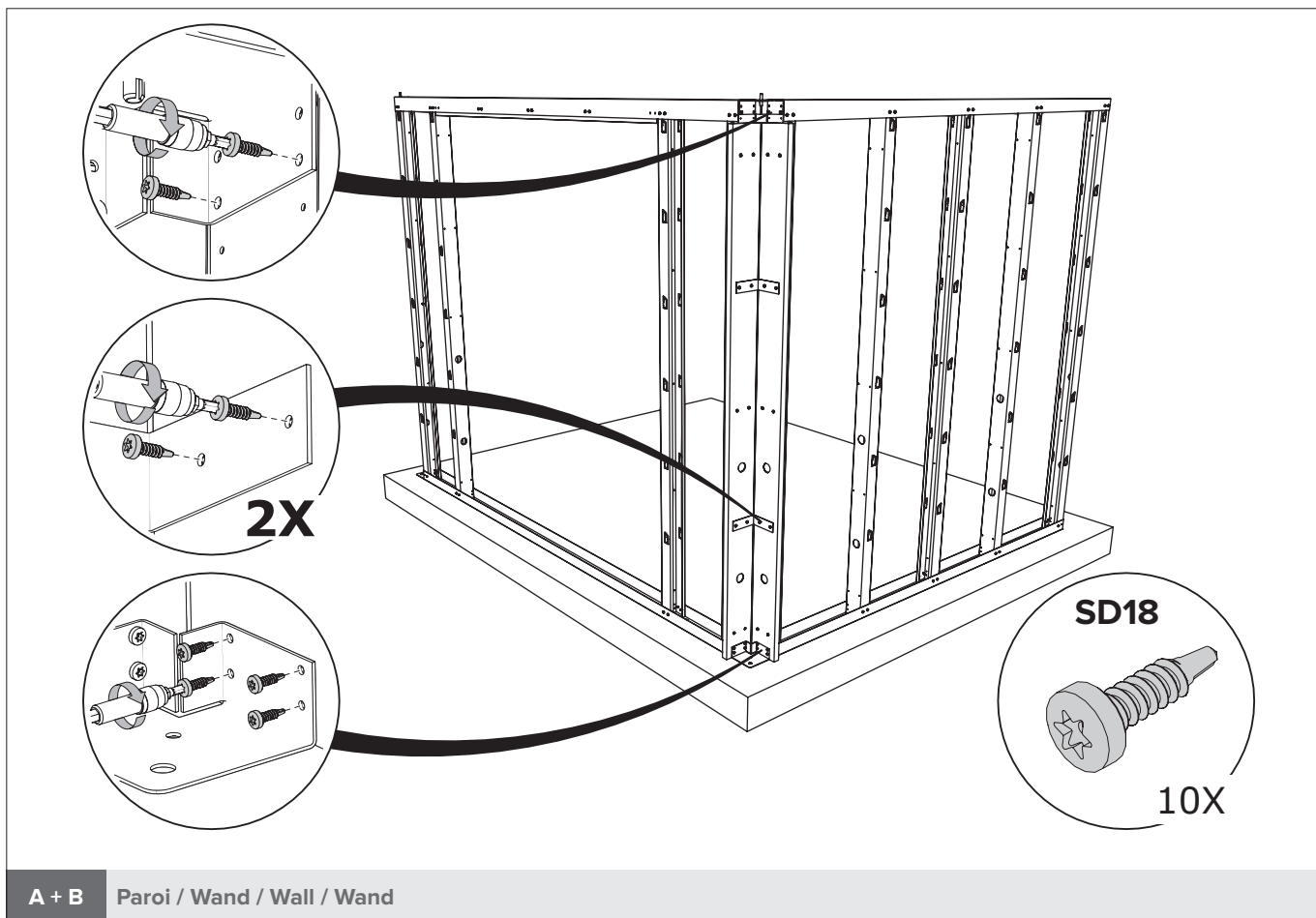

**Option Dekorputz:**

Plier les crochets à 90°  
 Hoekjes plooiën op 90°  
 Corners fold at 90°  
 Ecken um 90° falten

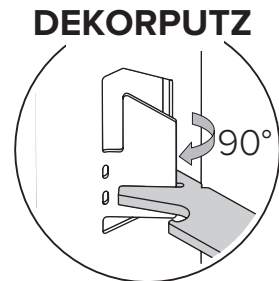
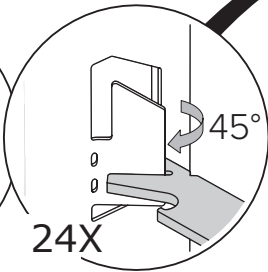
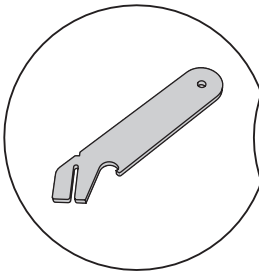
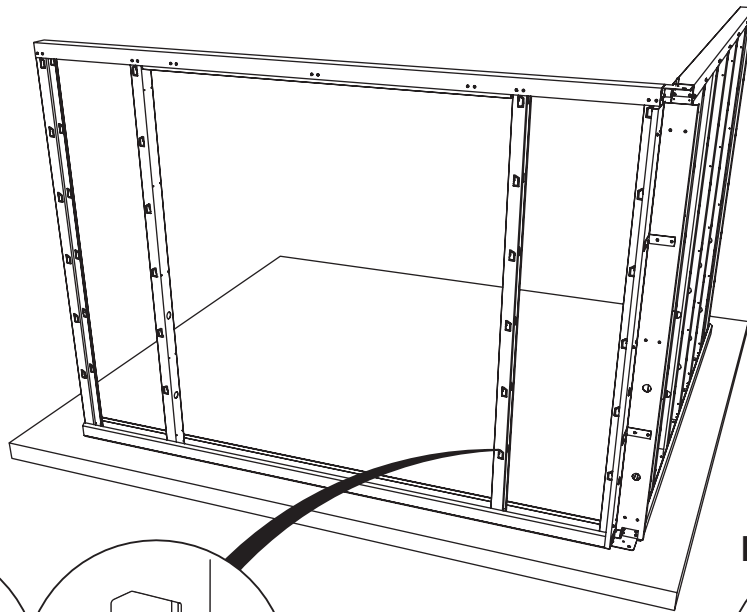

**DEKORPUTZ**

A + B Paroi / Wand / Wall / Wand

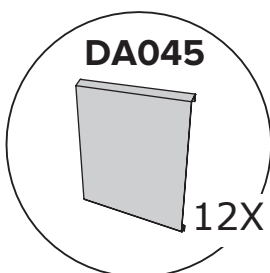
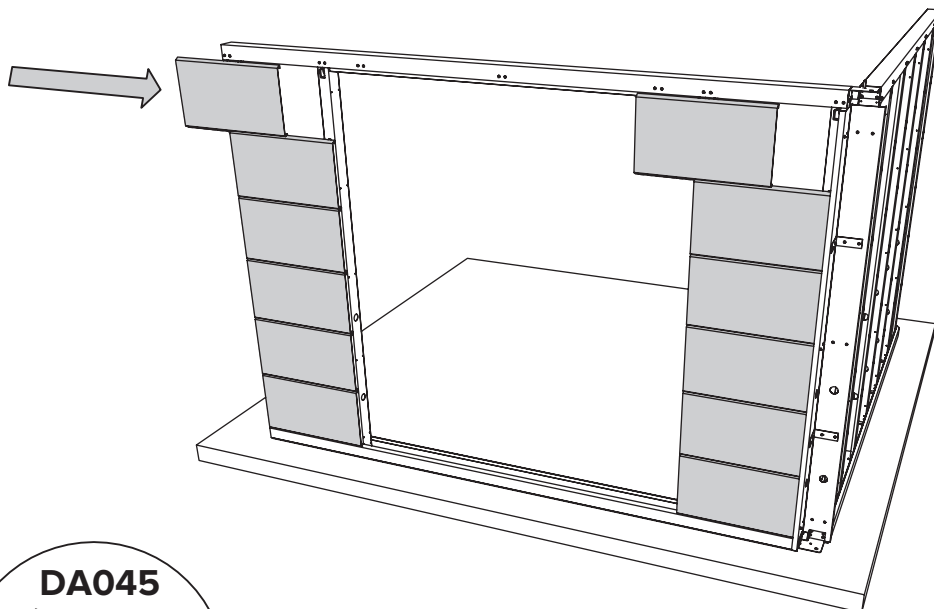

A + B Paroi / Wand / Wall / Wand

**Option Dekorputz:**

Plier les crochets à 90°  
 Hoekjes plooiën op 90°  
 Corners fold at 90°  
 Ecken um 90° falten

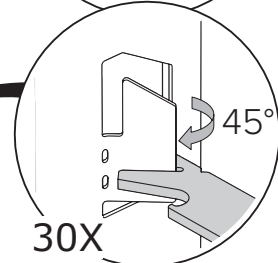
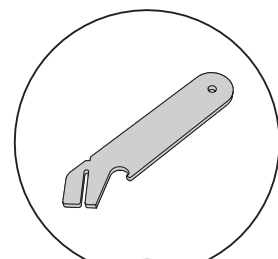
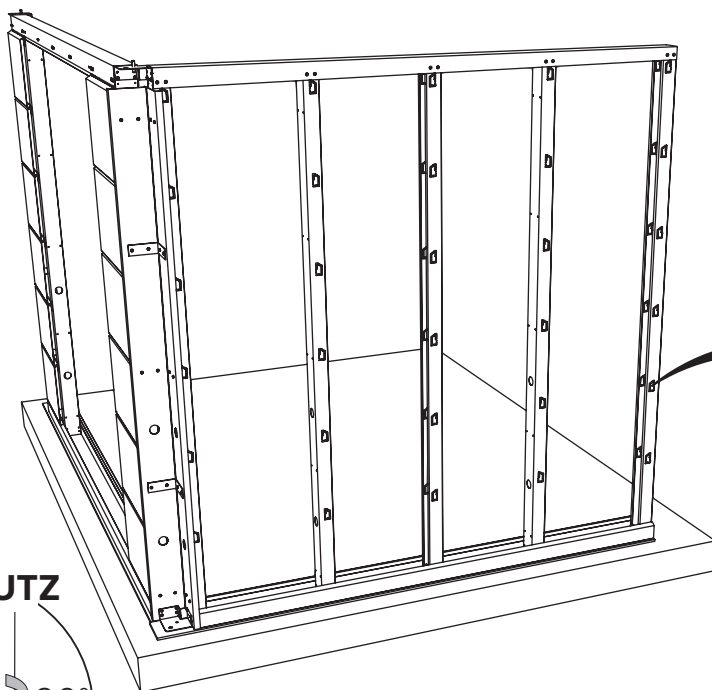

**DEKORPUTZ**

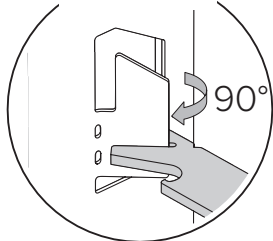

A + B Paroi / Wand / Wall / Wand

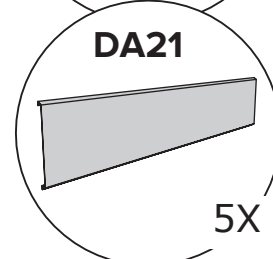
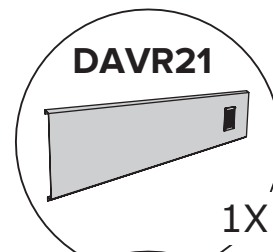
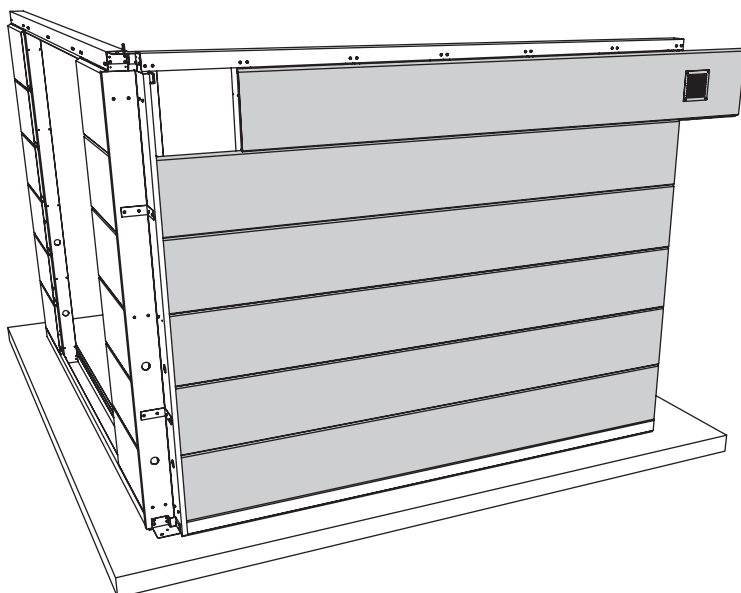

A + B Paroi / Wand / Wall / Wand

revêtement intérieur  
 binnenbekleding  
 interior lining  
 Innenverkleidung

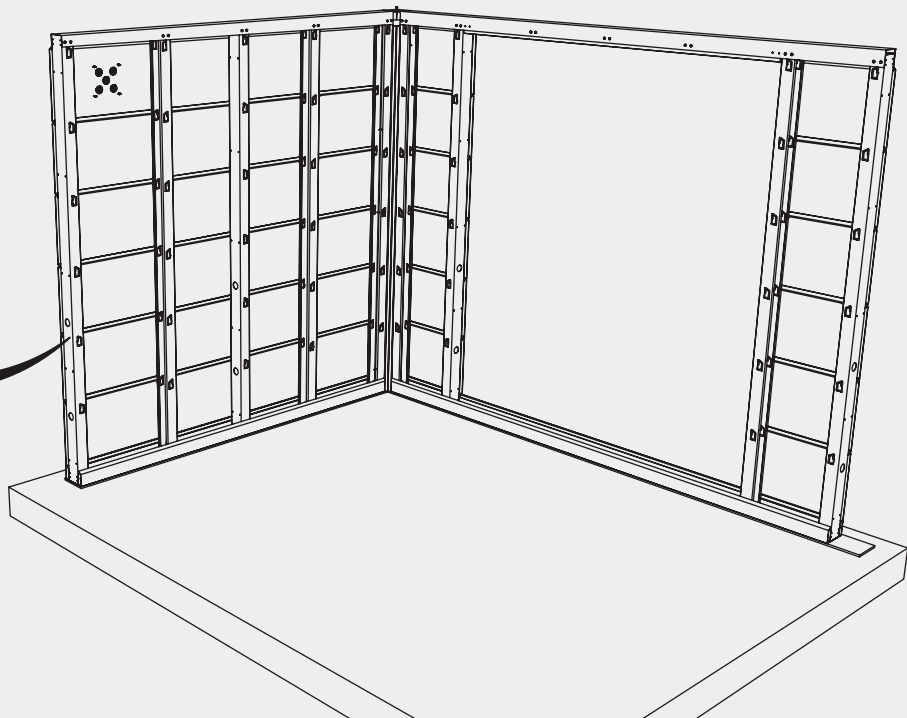
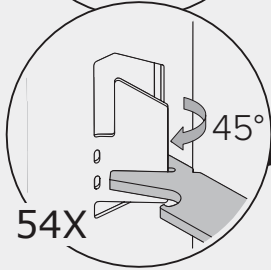
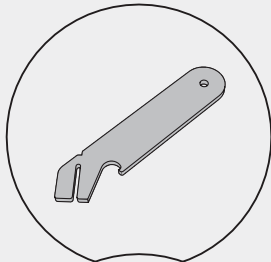

A + B Paroi / Wand / Wall / Wand

Option / Optie / Option / Option

revêtement intérieur  
 binnenbekleding  
 interior lining  
 Innenverkleidung

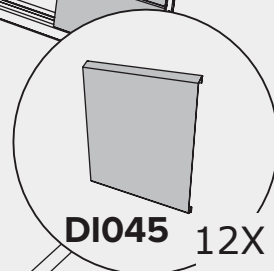
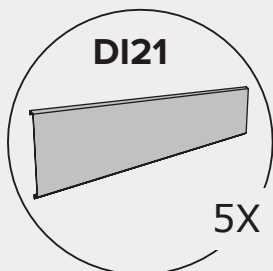
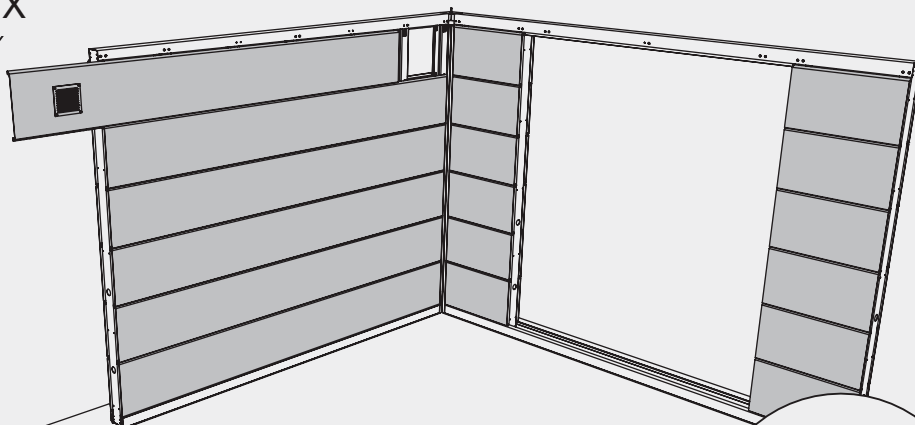
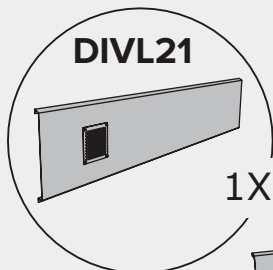

A + B Paroi / Wand / Wall / Wand

Option / Optie / Option / Option

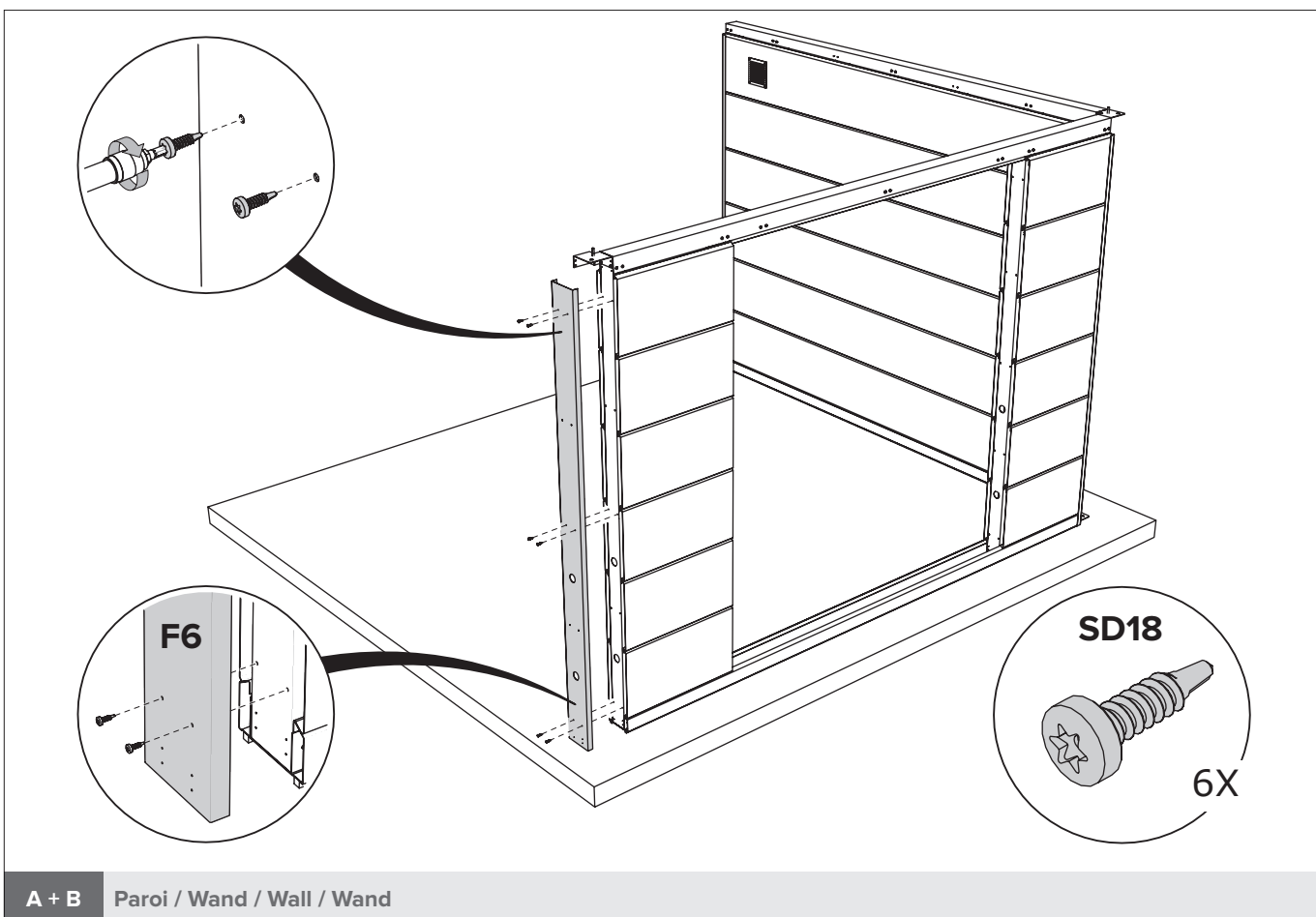
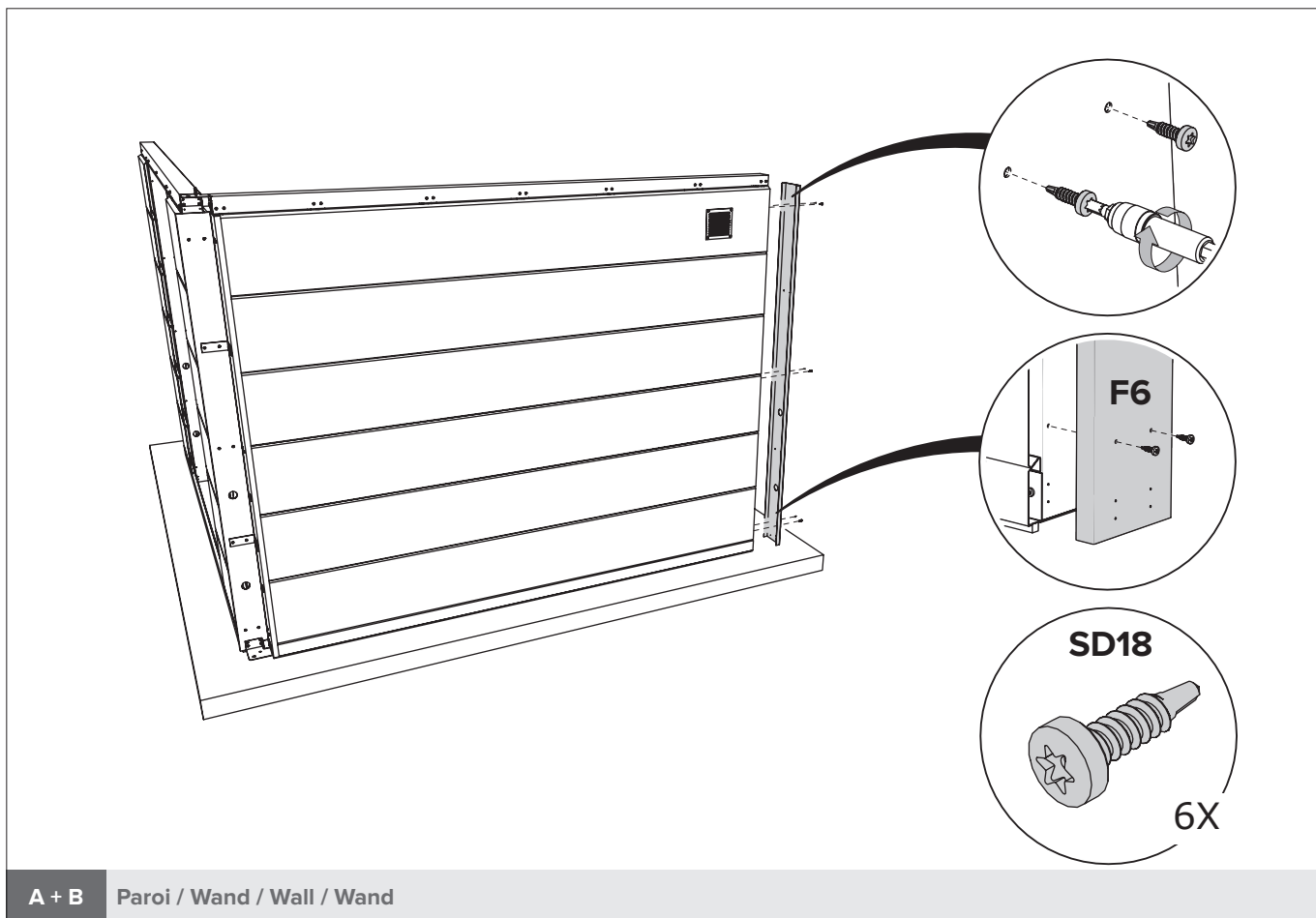

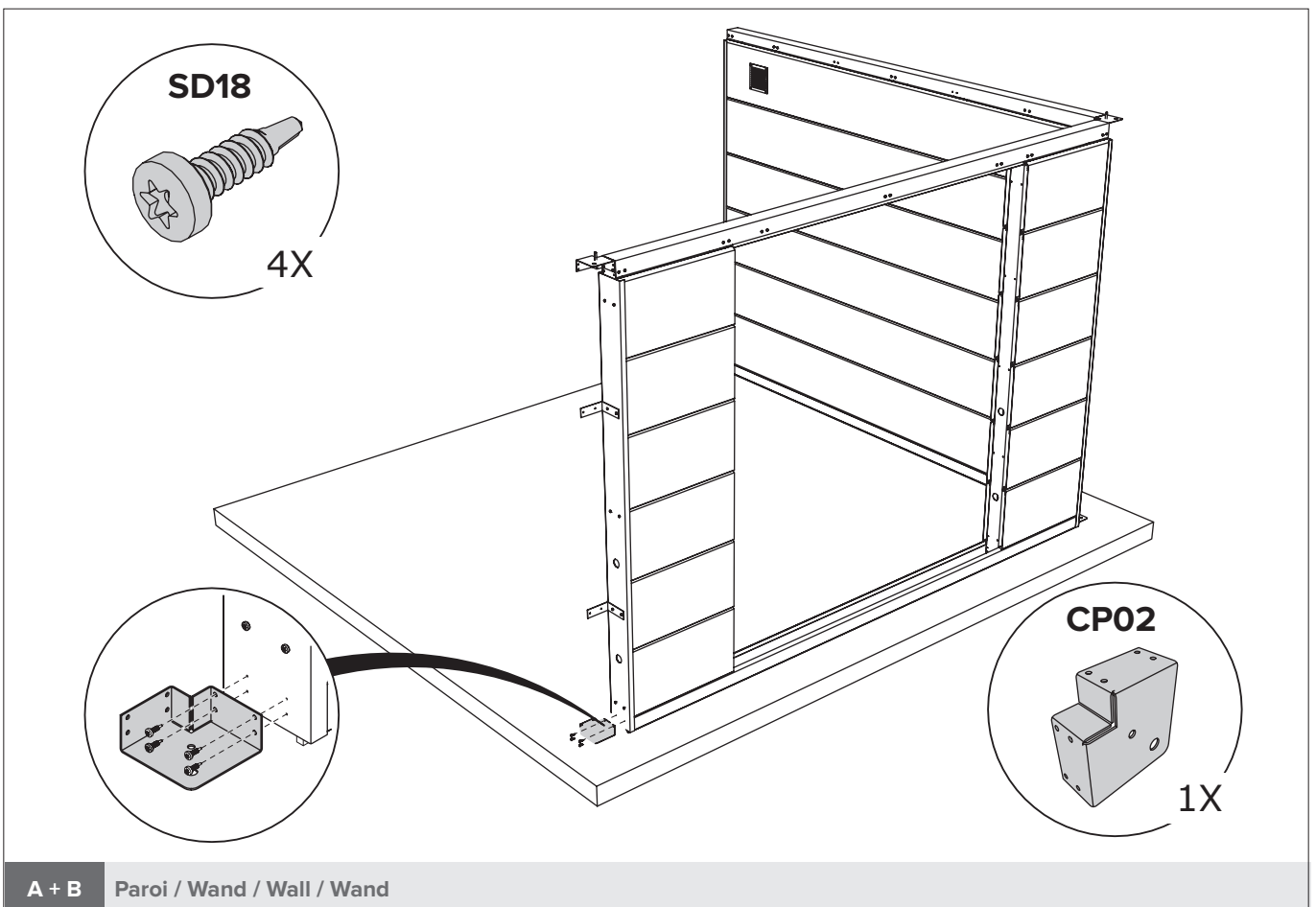
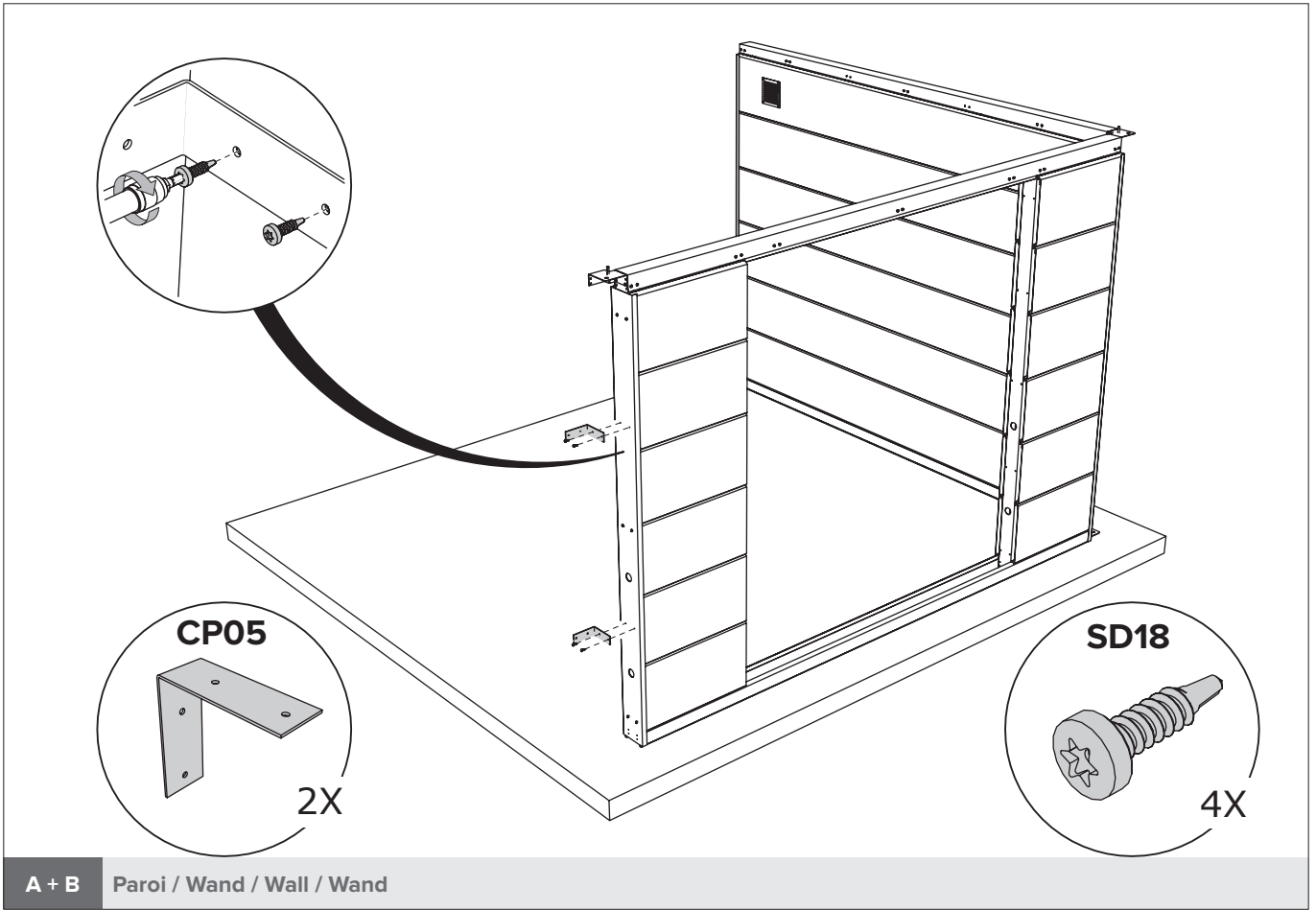

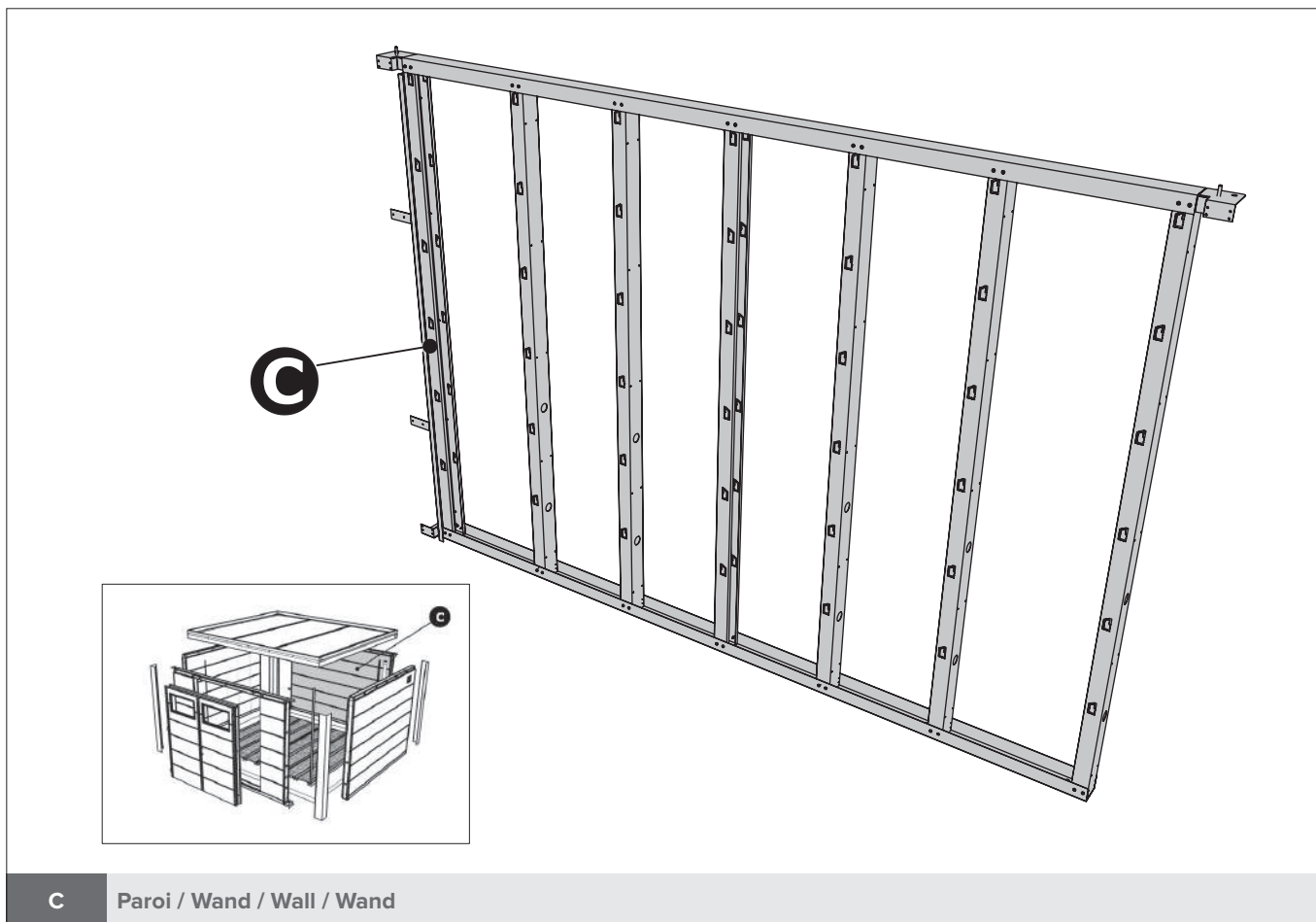

Le principe de la construction du mur, voir pages 8 à 11.  
 Het principe van de opbouw van de wand, zie pagina 8 tot en met 11.  
 The principle of building the wall, see pages 8 through 11.  
 Das Prinzip des Baus der Mauer finden Sie auf den Seiten 8 bis 11.

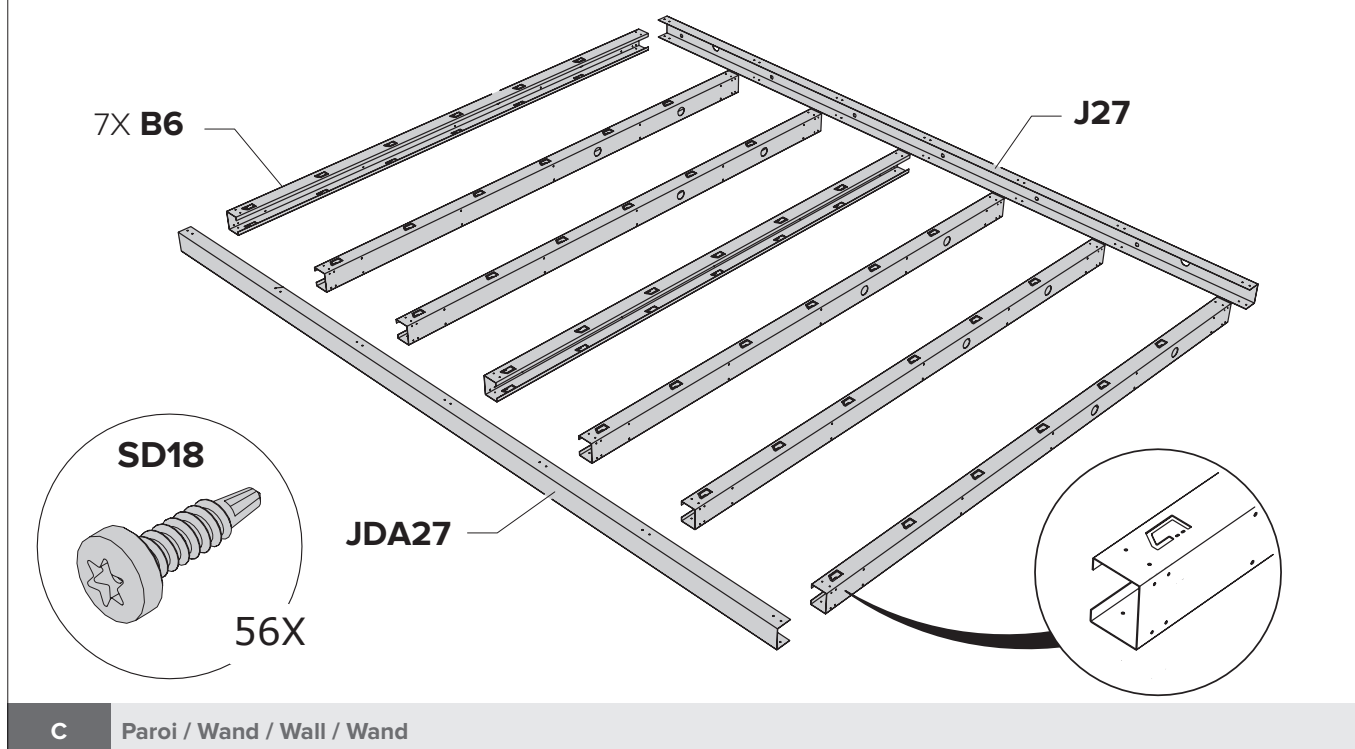



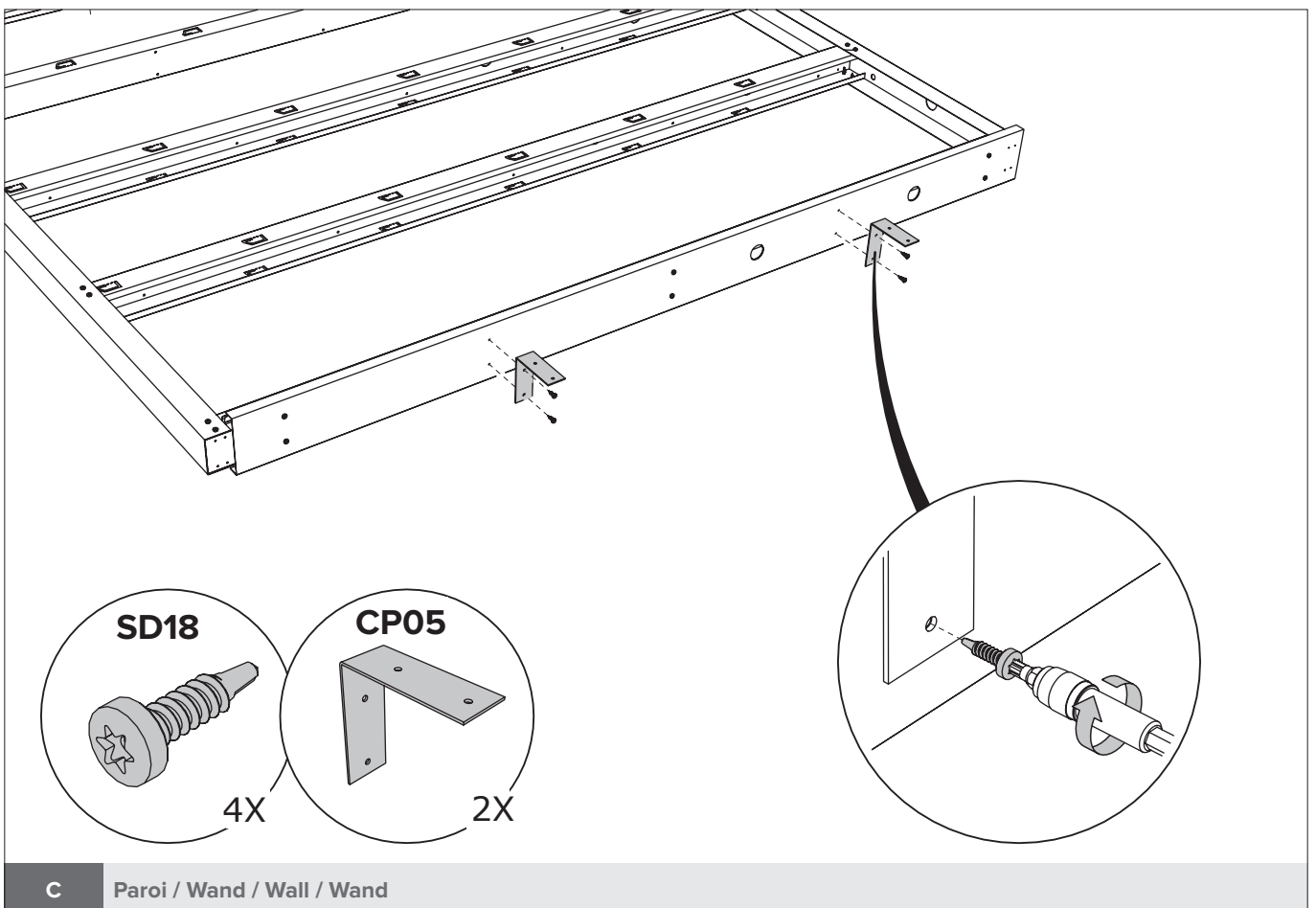
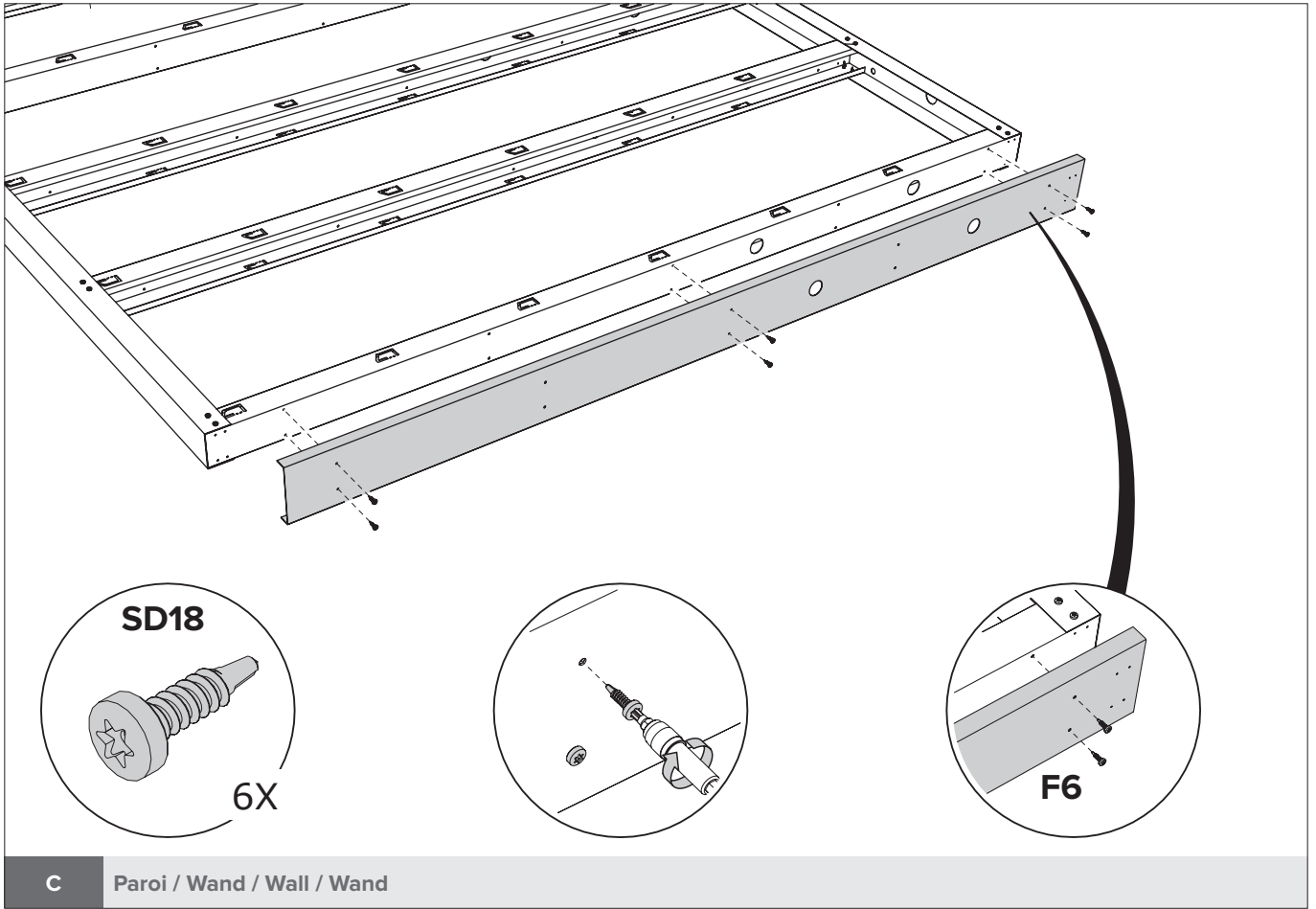

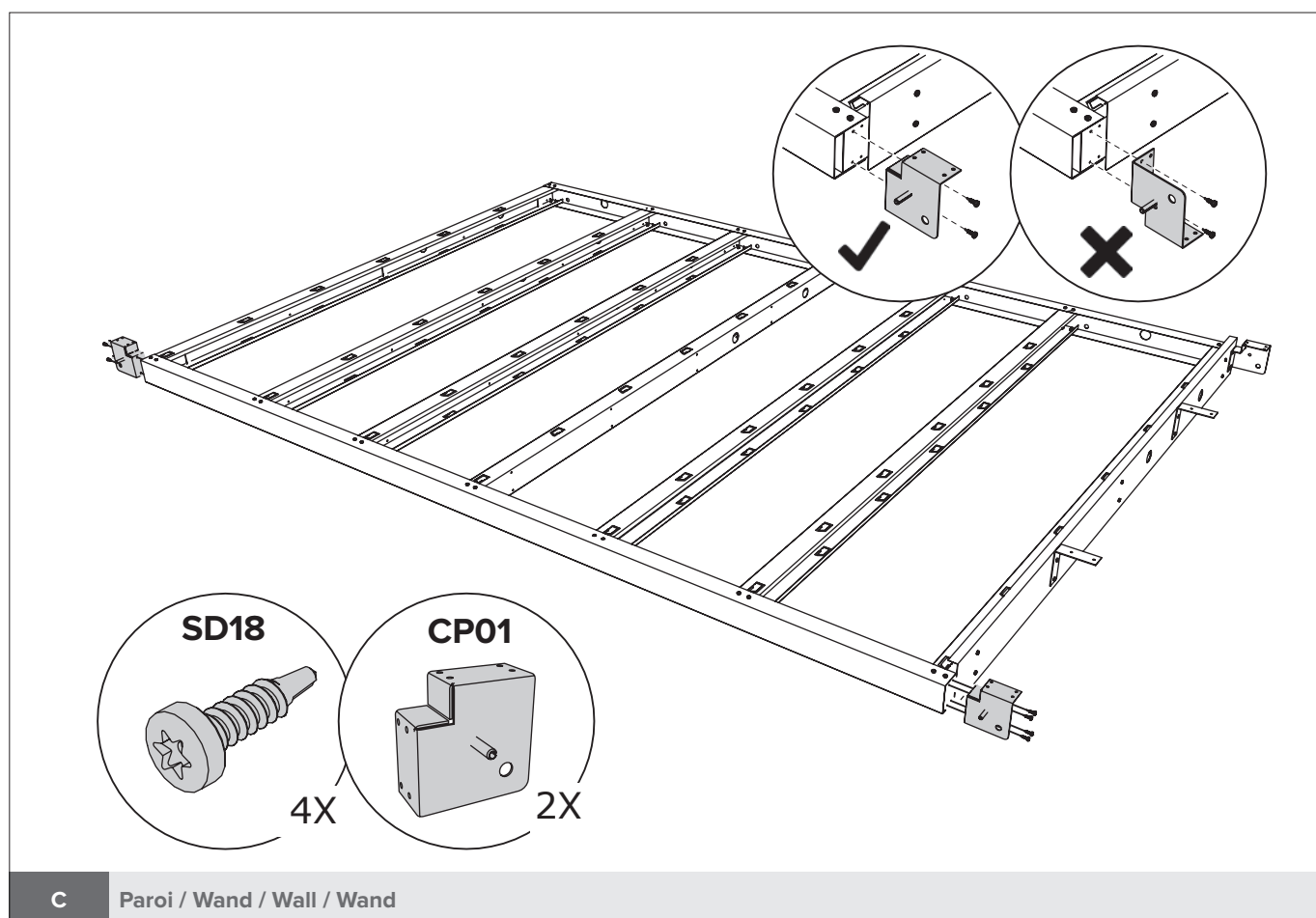
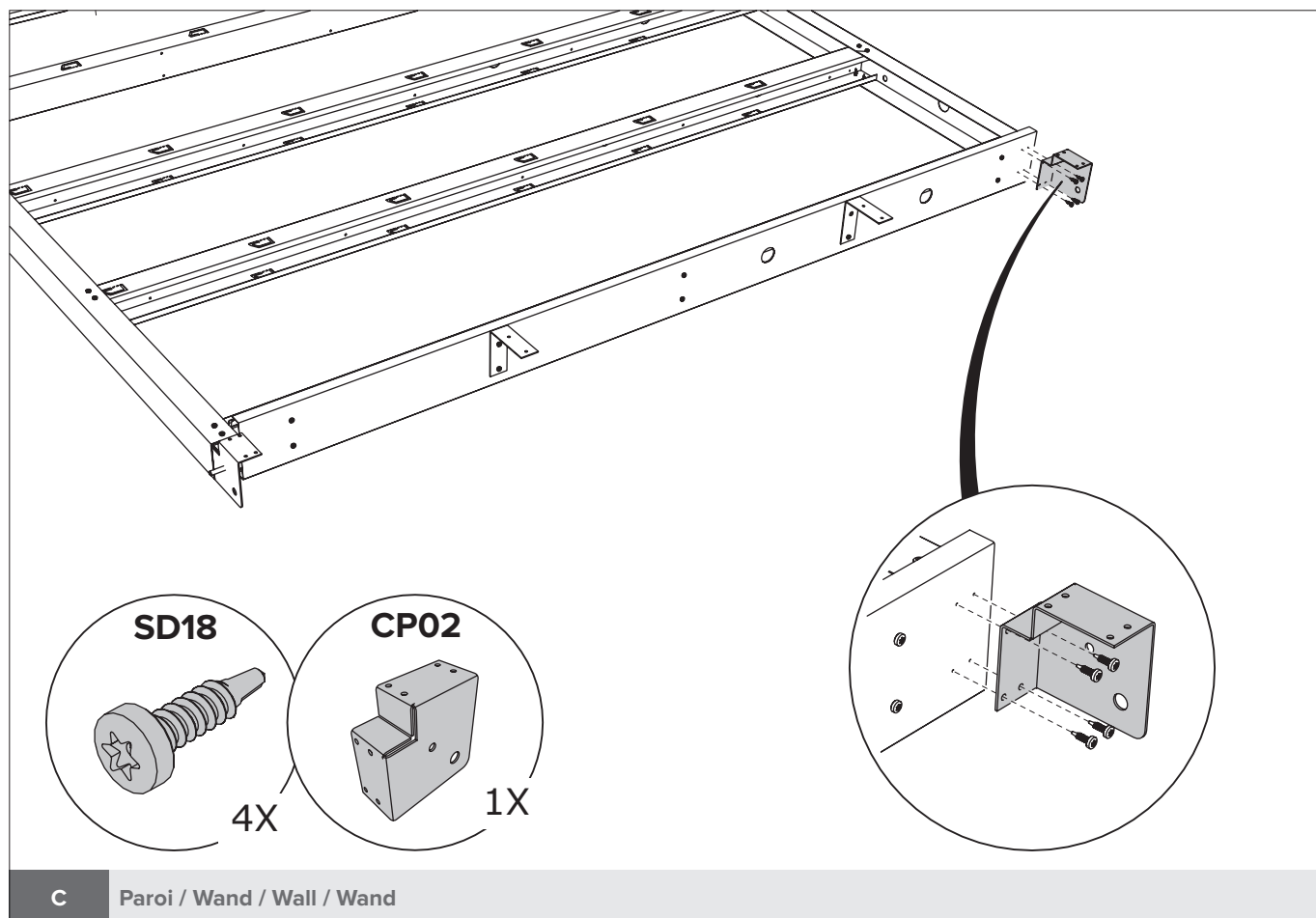

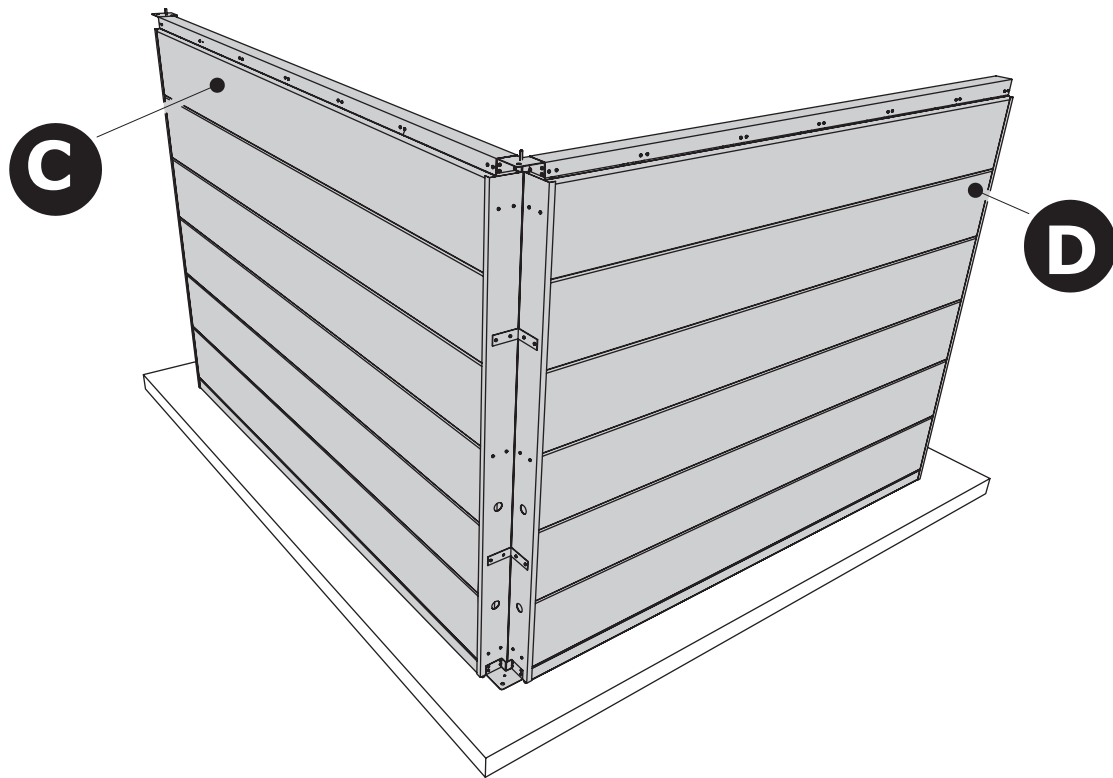

C + D Paroi / Wand / Wall / Wand

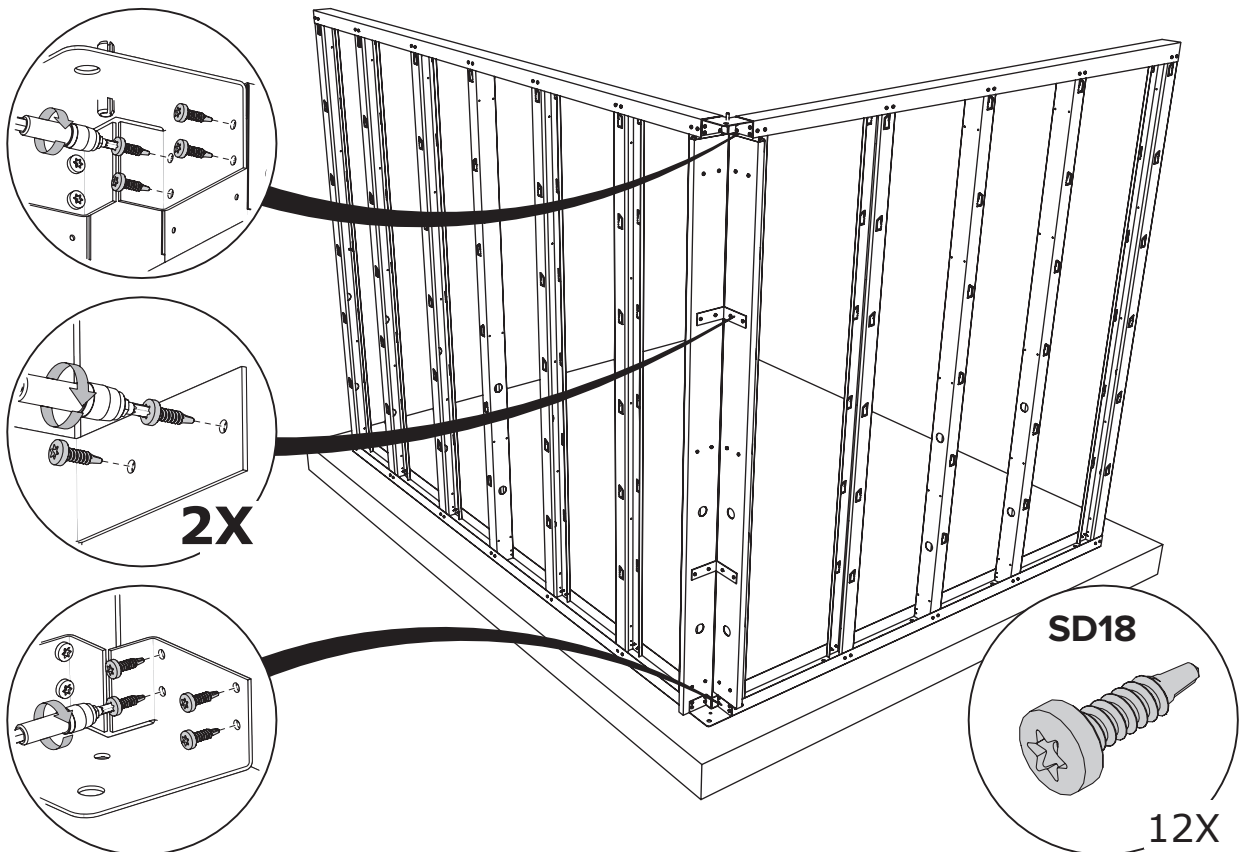

C + D Paroi / Wand / Wall / Wand

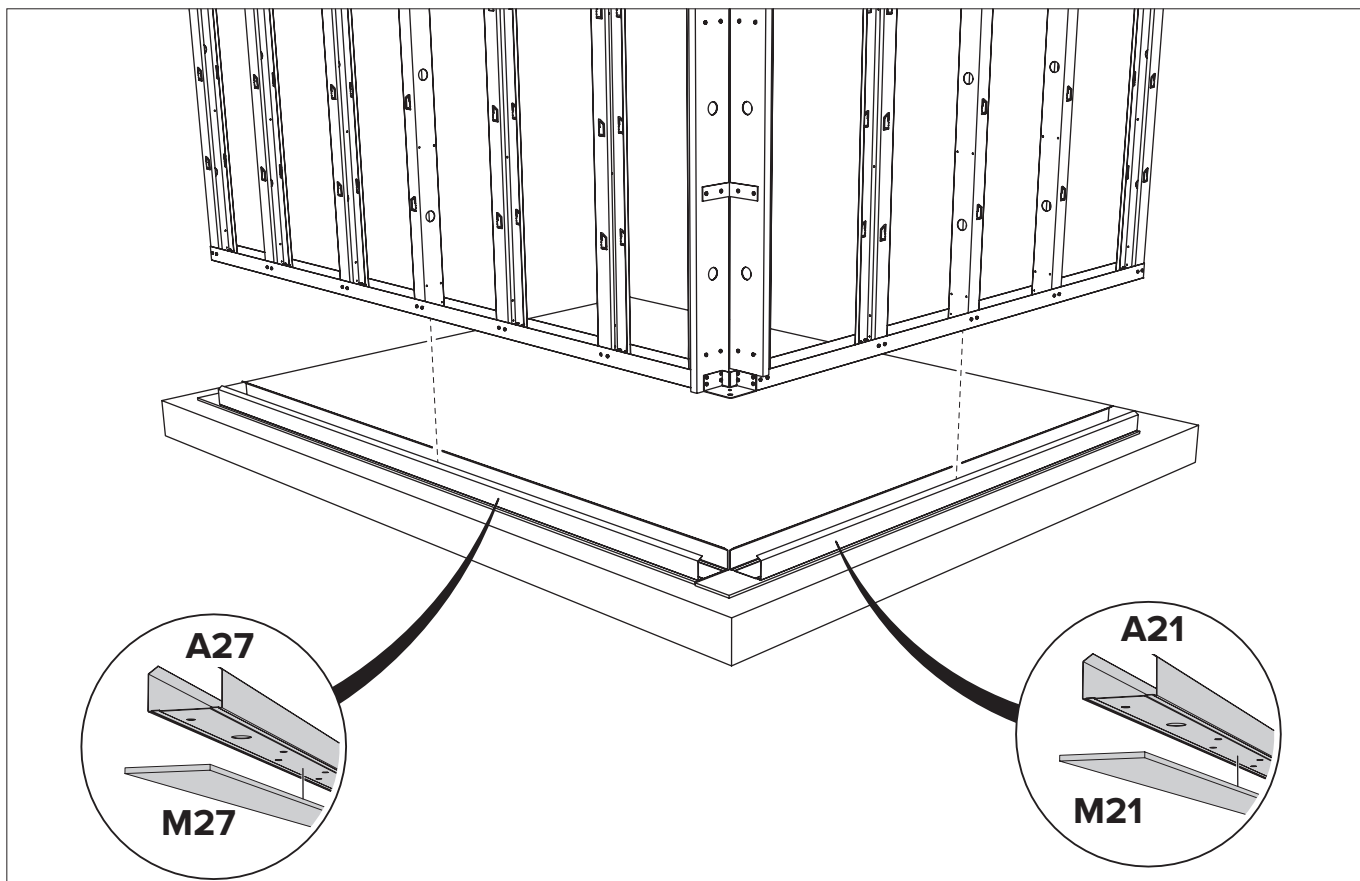

C + D Paroi / Wand / Wall / Wand

**Option Dekorputz:**

Plier les crochets à 90°  
 Hoekjes plooiën op 90°  
 Corners fold at 90°  
 Ecken um 90° falten

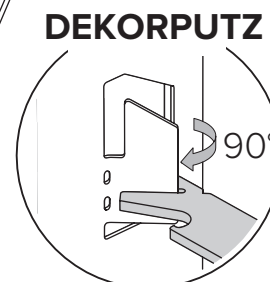
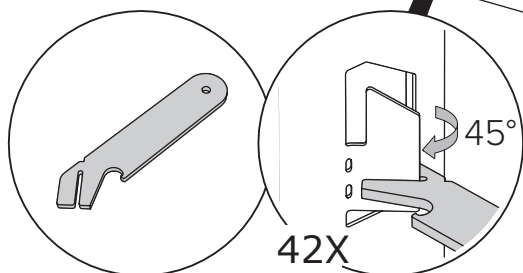
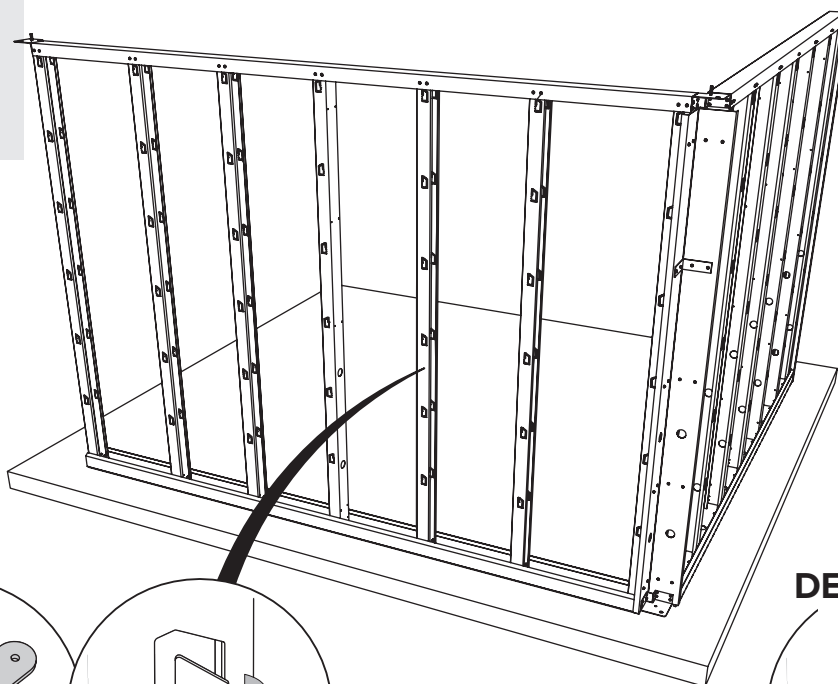

C + D Paroi / Wand / Wall / Wand

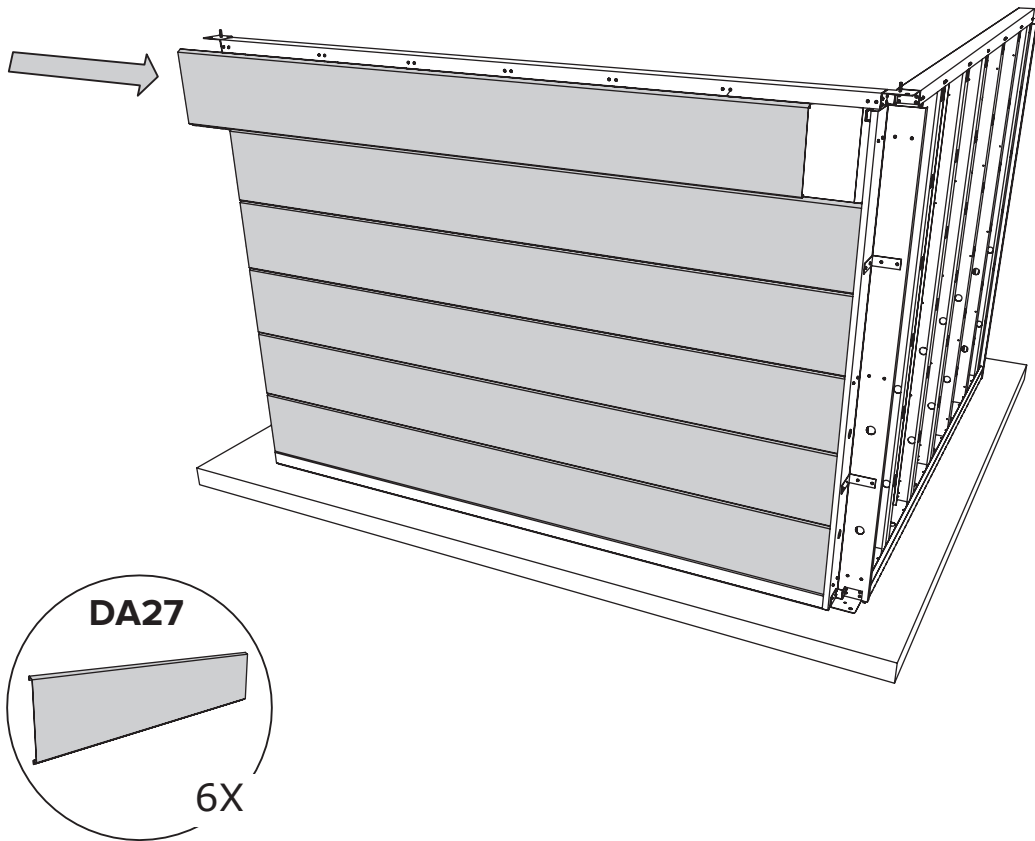

C + D Paroi / Wand / Wall / Wand

**Option Dekorputz:**

Plier les crochets à 90°  
 Hoekjes plooiën op 90°  
 Corners fold at 90°  
 Ecken um 90° falten

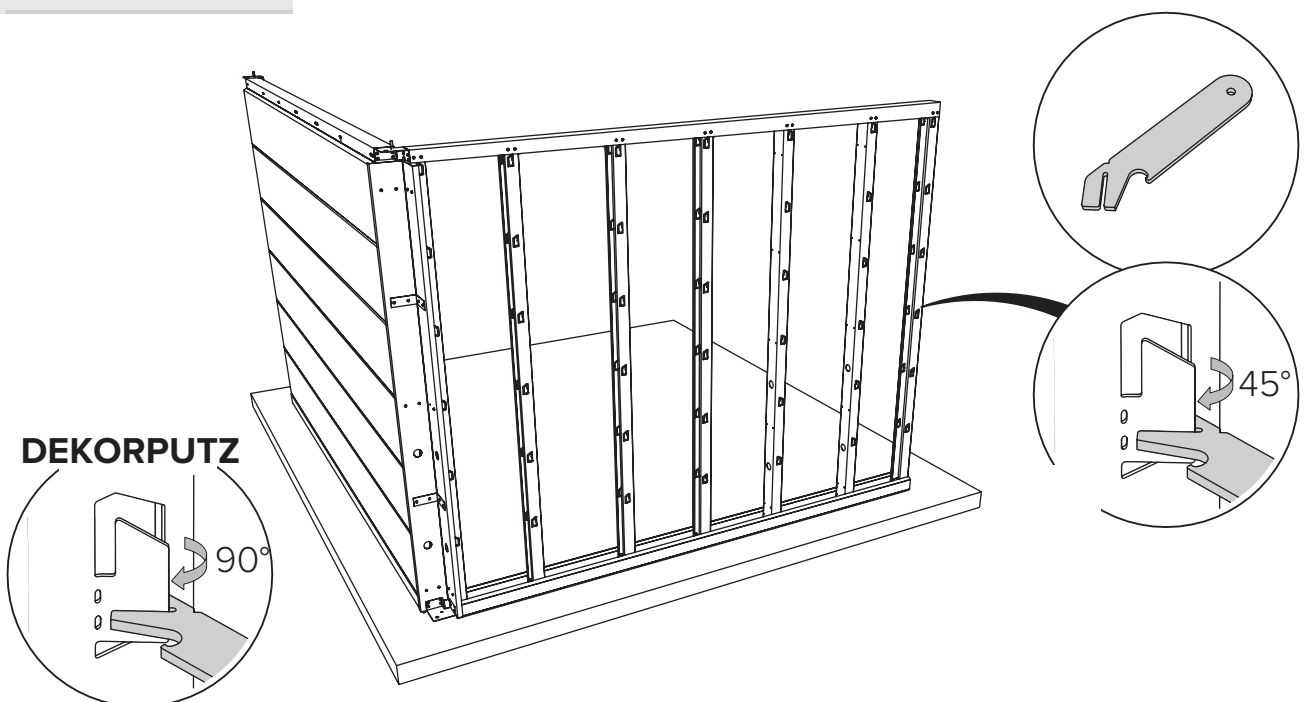

C + D Paroi / Wand / Wall / Wand

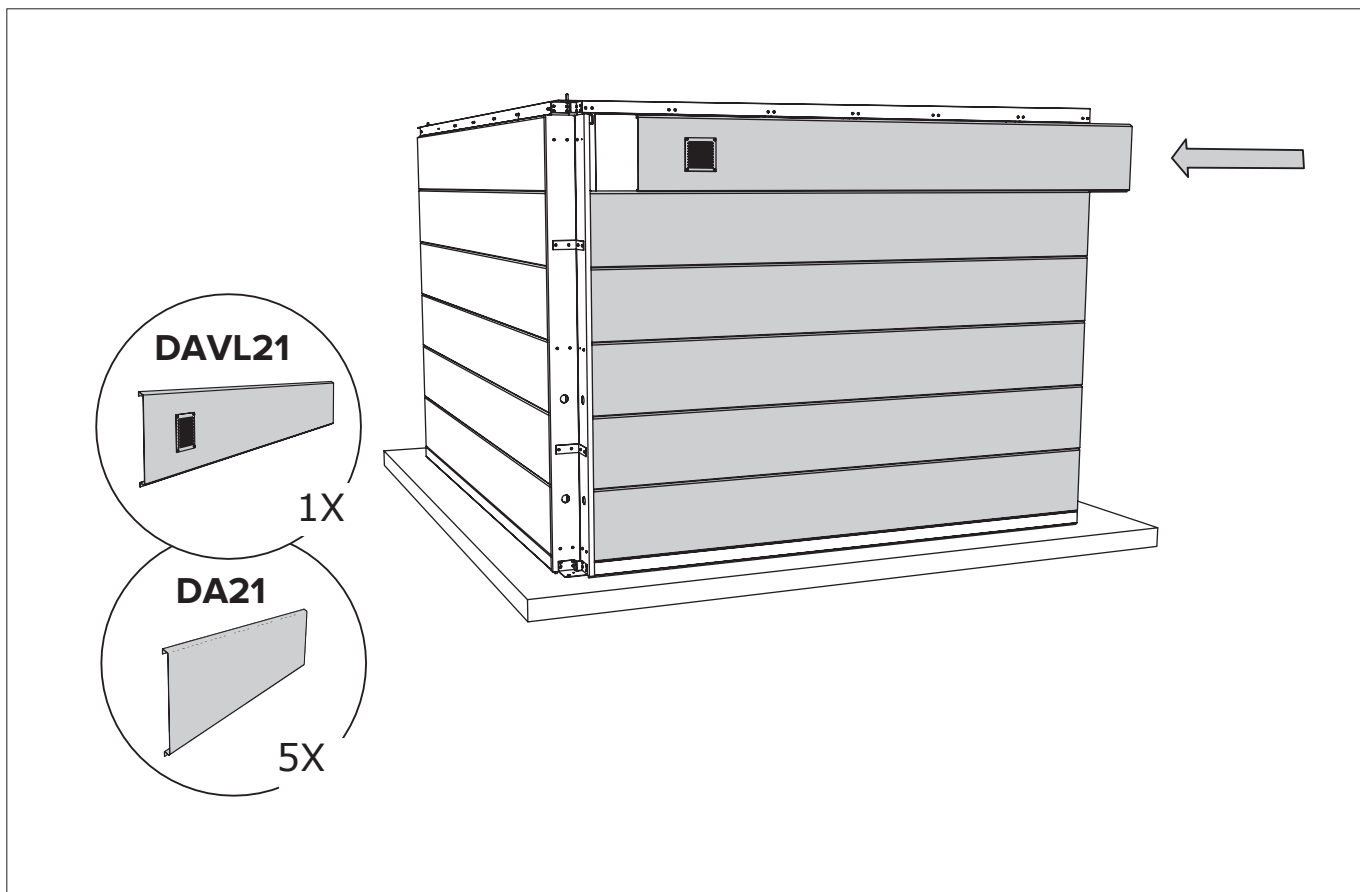

C + D Paroi / Wand / Wall / Wand

revêtement intérieur  
binnenbekleding  
interior lining  
Innenverkleidung

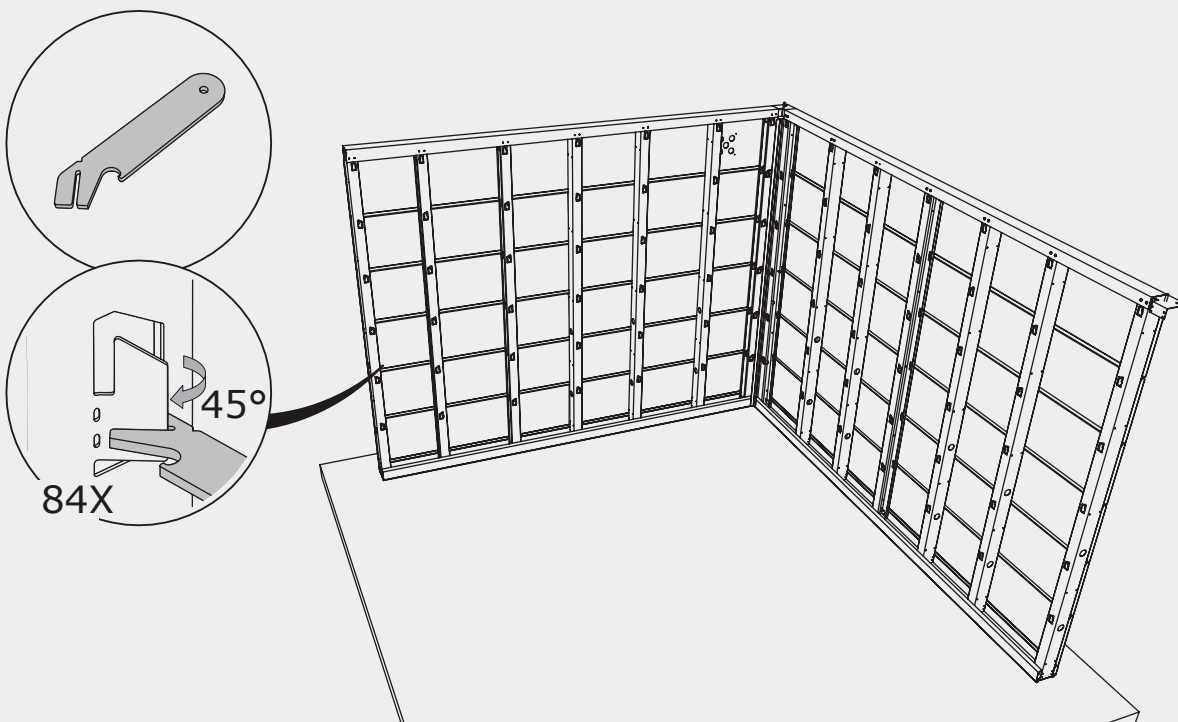

C + D Paroi / Wand / Wall / Wand

Option / Optie / Option / Option

revêtement intérieur et plaque perforée  
 binnenbekleding en geperforeerde plaat  
 interior lining and perforated plate  
 Innenverkleidung und perforierte Platte

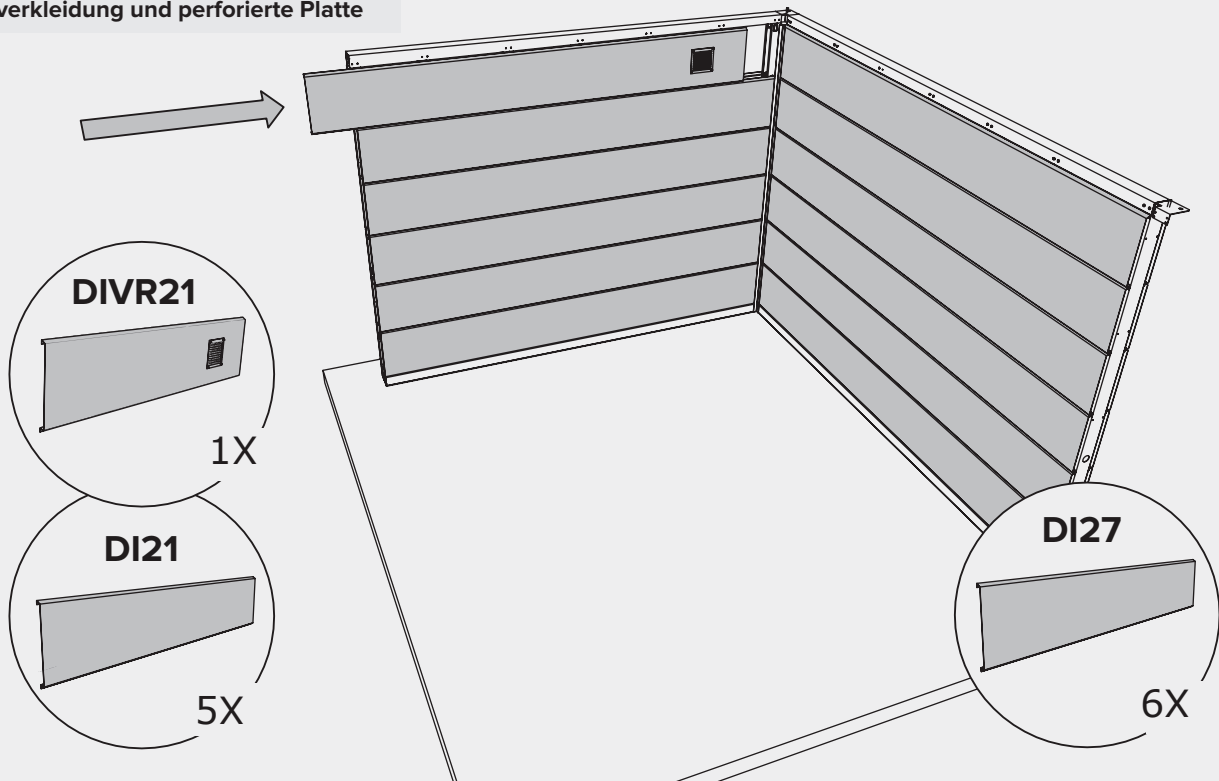

C+ D Paroi / Wand / Wall / Wand

Option / Optie / Option / Option

revêtement intérieur et plaque perforée  
 binnenbekleding en geperforeerde plaat  
 interior lining and perforated plate  
 Innenverkleidung und perforierte Platte

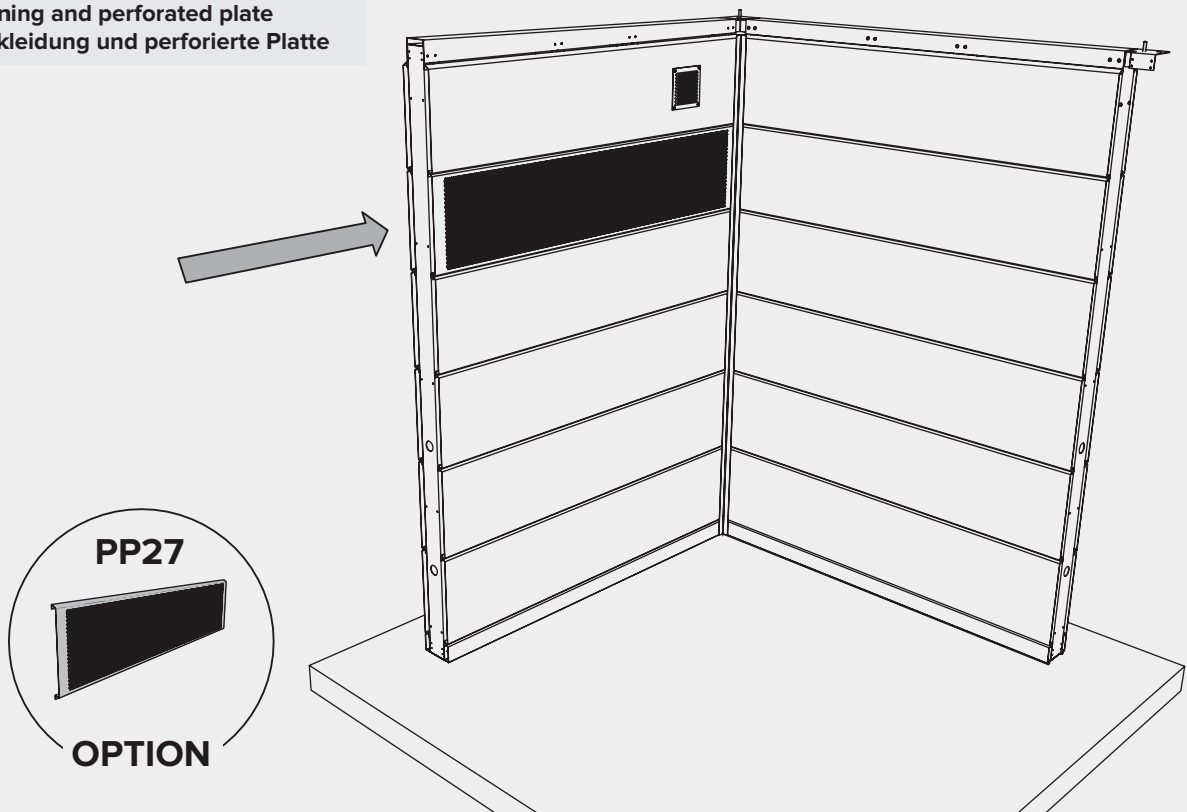

C+ D Paroi / Wand / Wall / Wand

Option / Optie / Option / Option

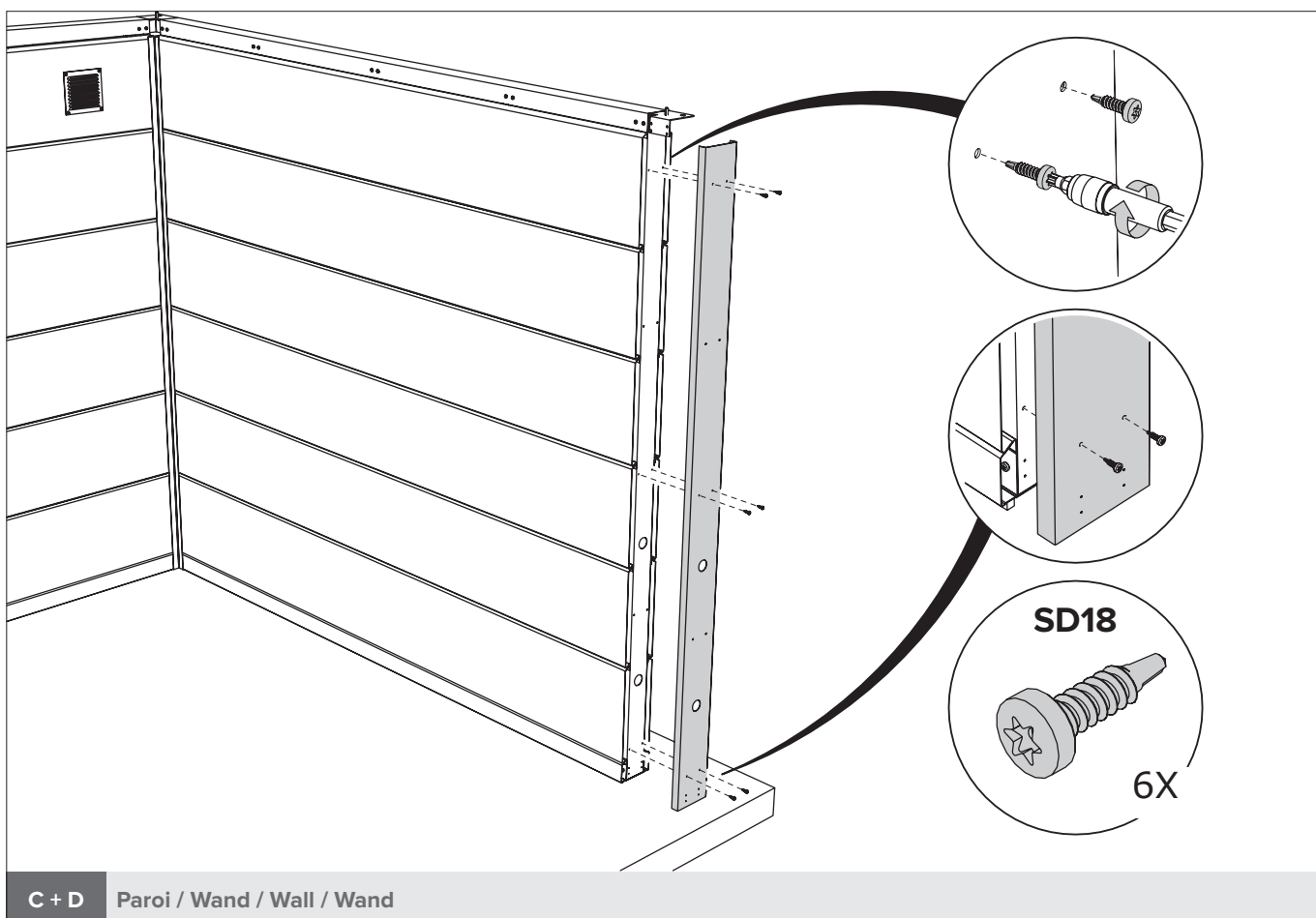
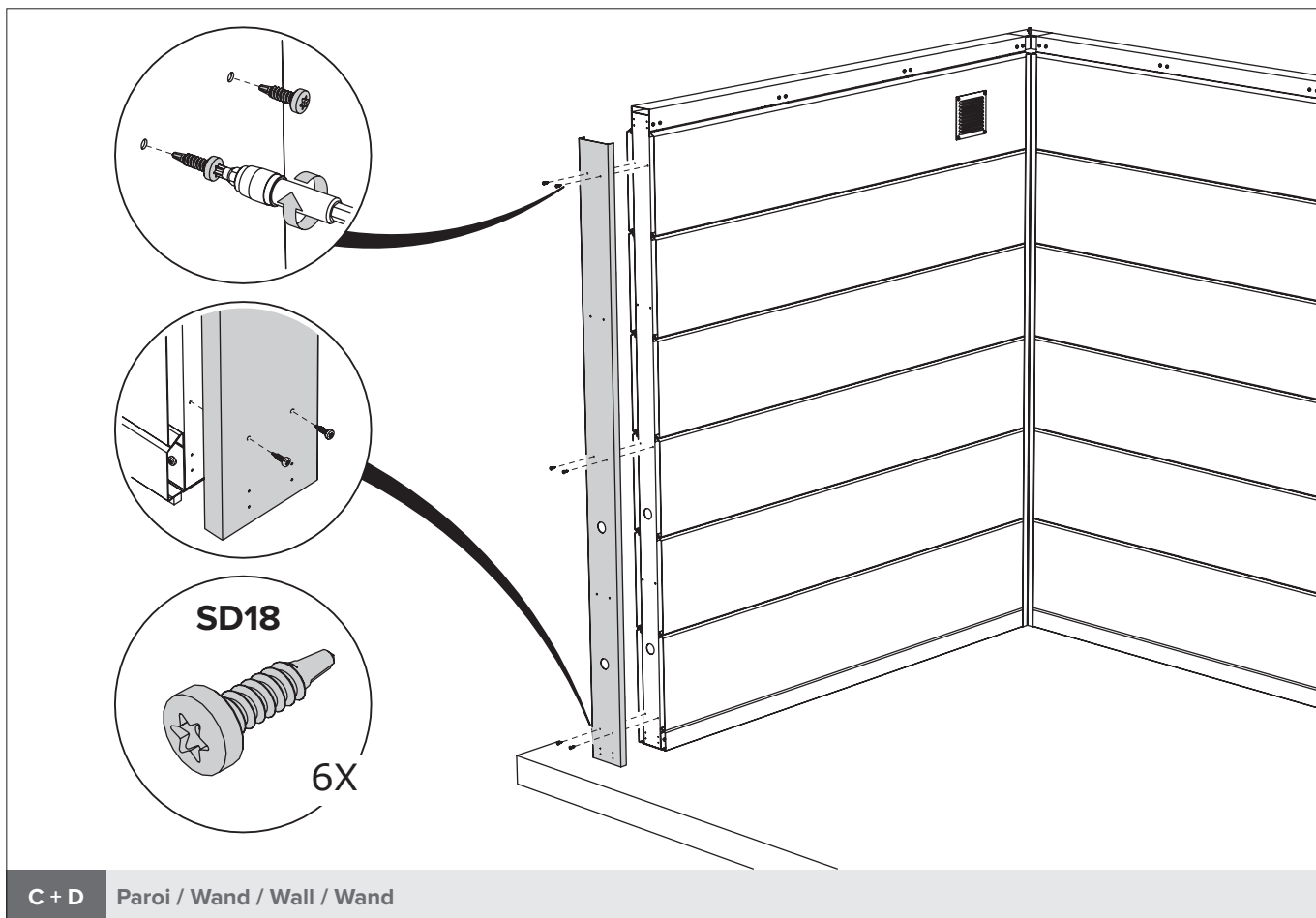



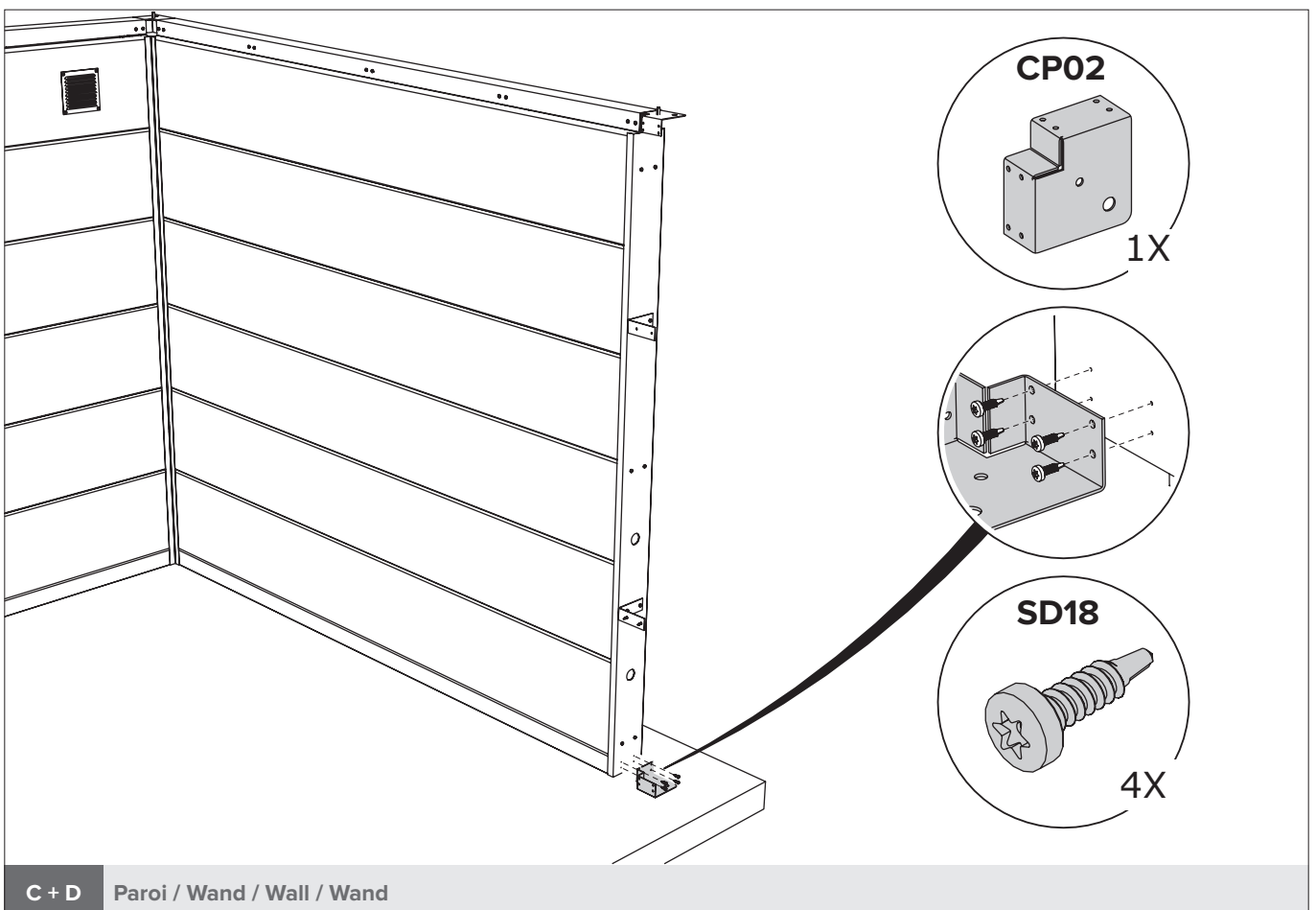
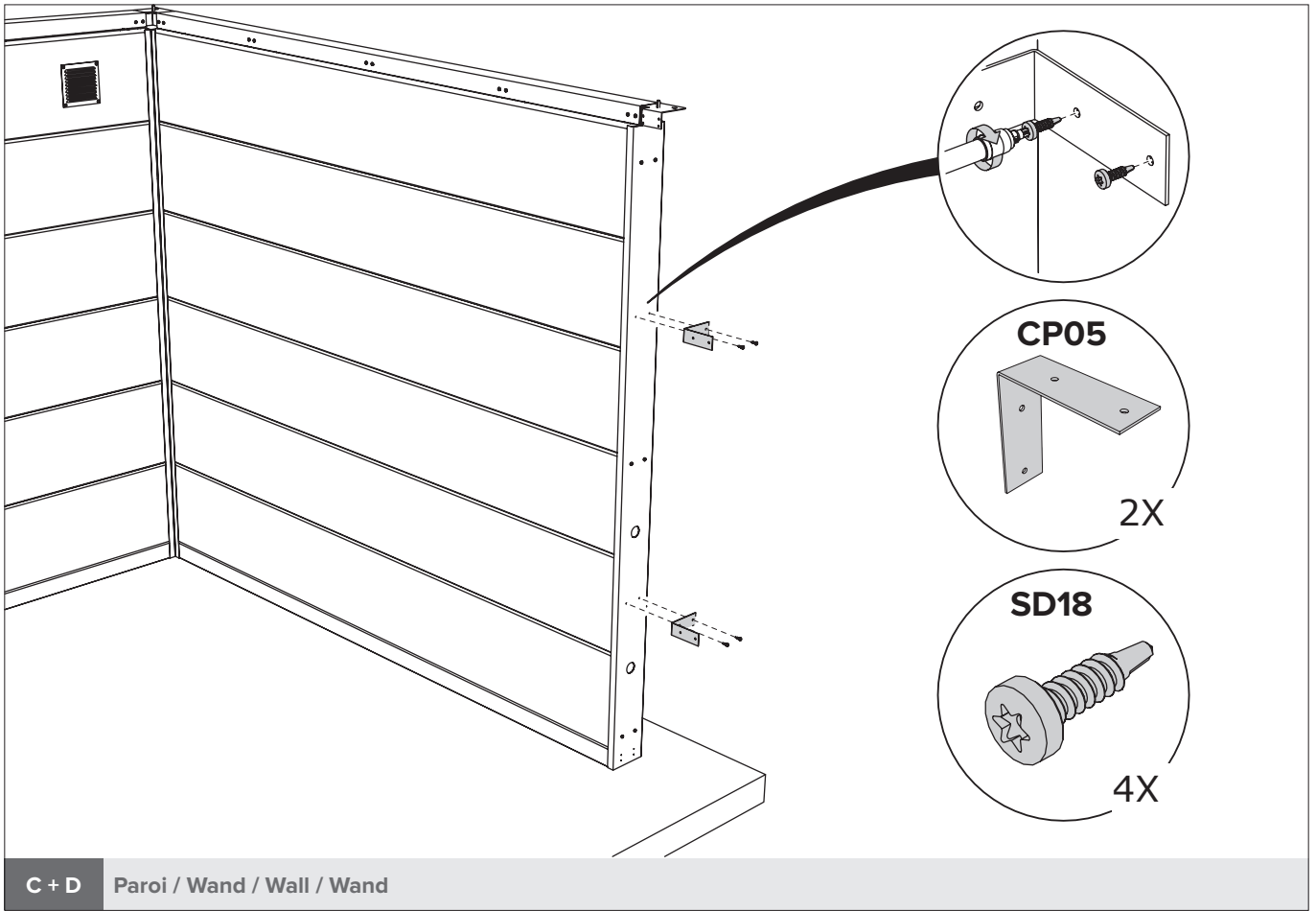

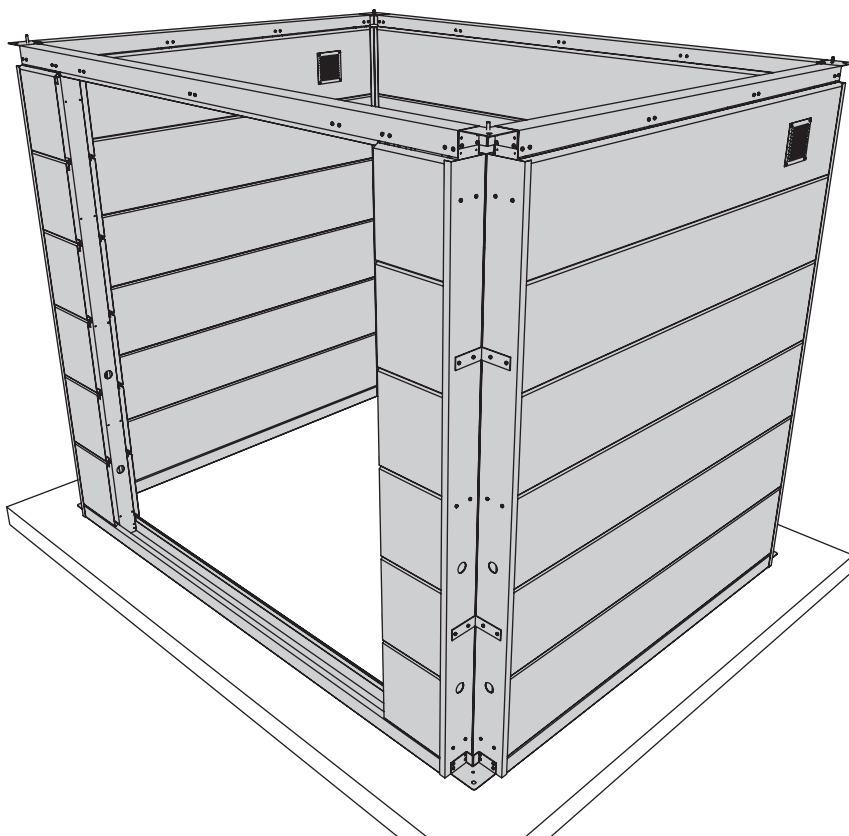

A + B + C + D Paroi / Wand / Wall / Wand

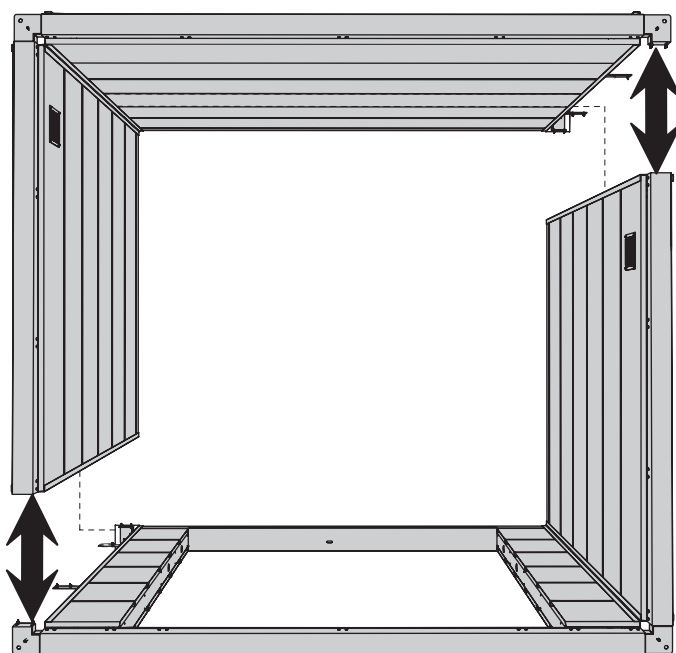

A + B + C + D Paroi / Wand / Wall / Wand

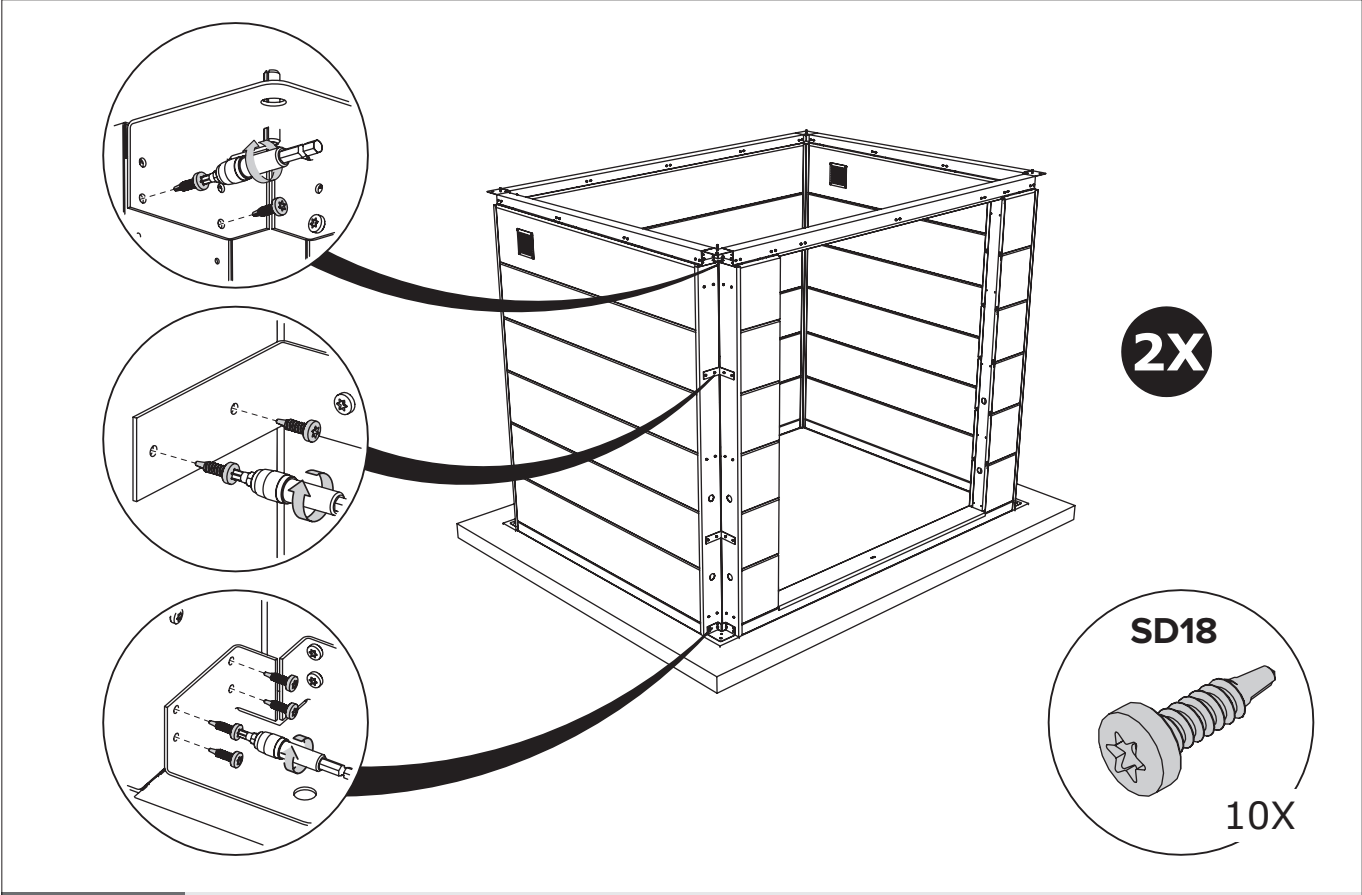

A + B + C + D Paroi / Wand / Wall / Wand

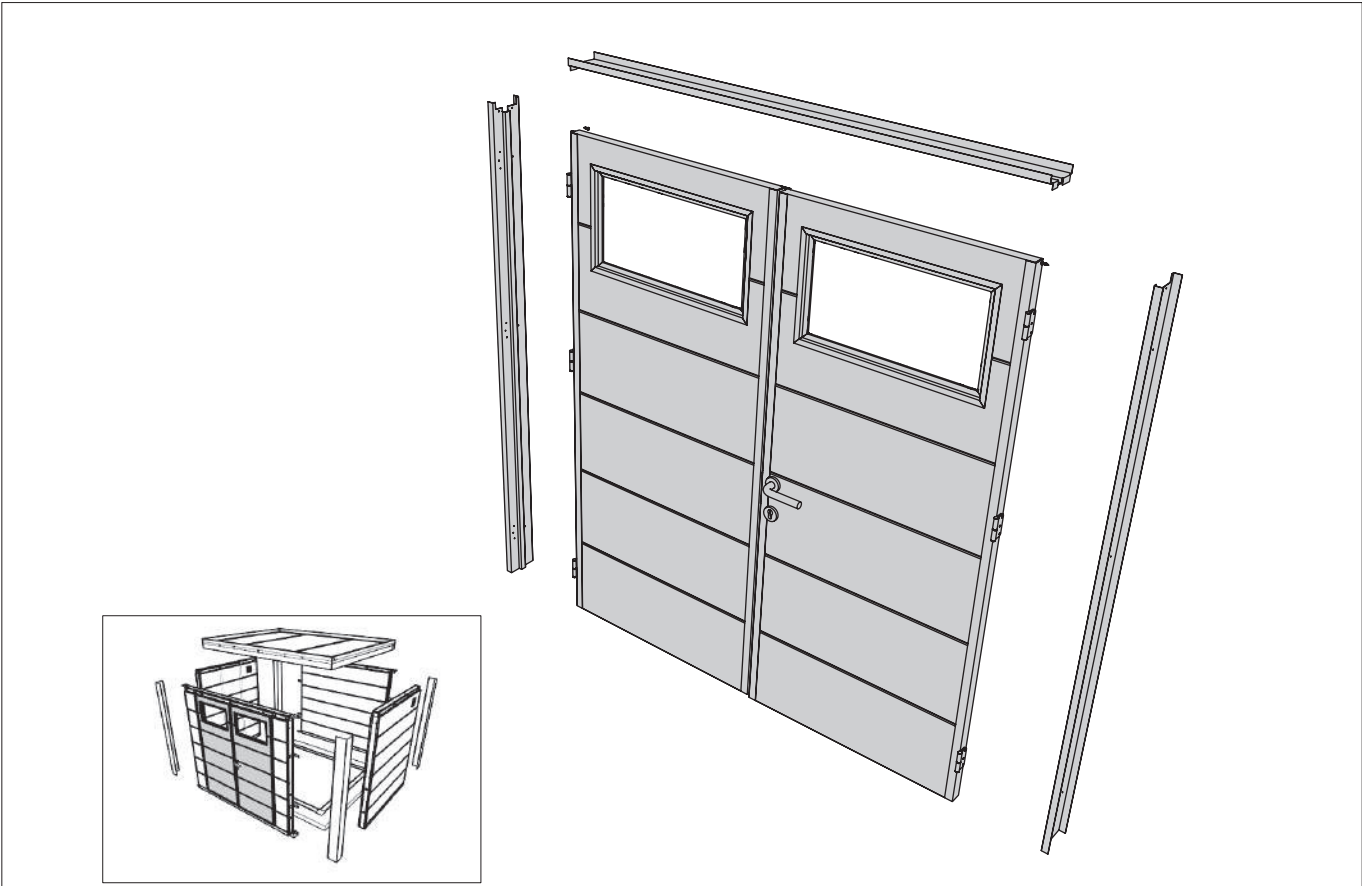

Porte / Deur / Door / Tür

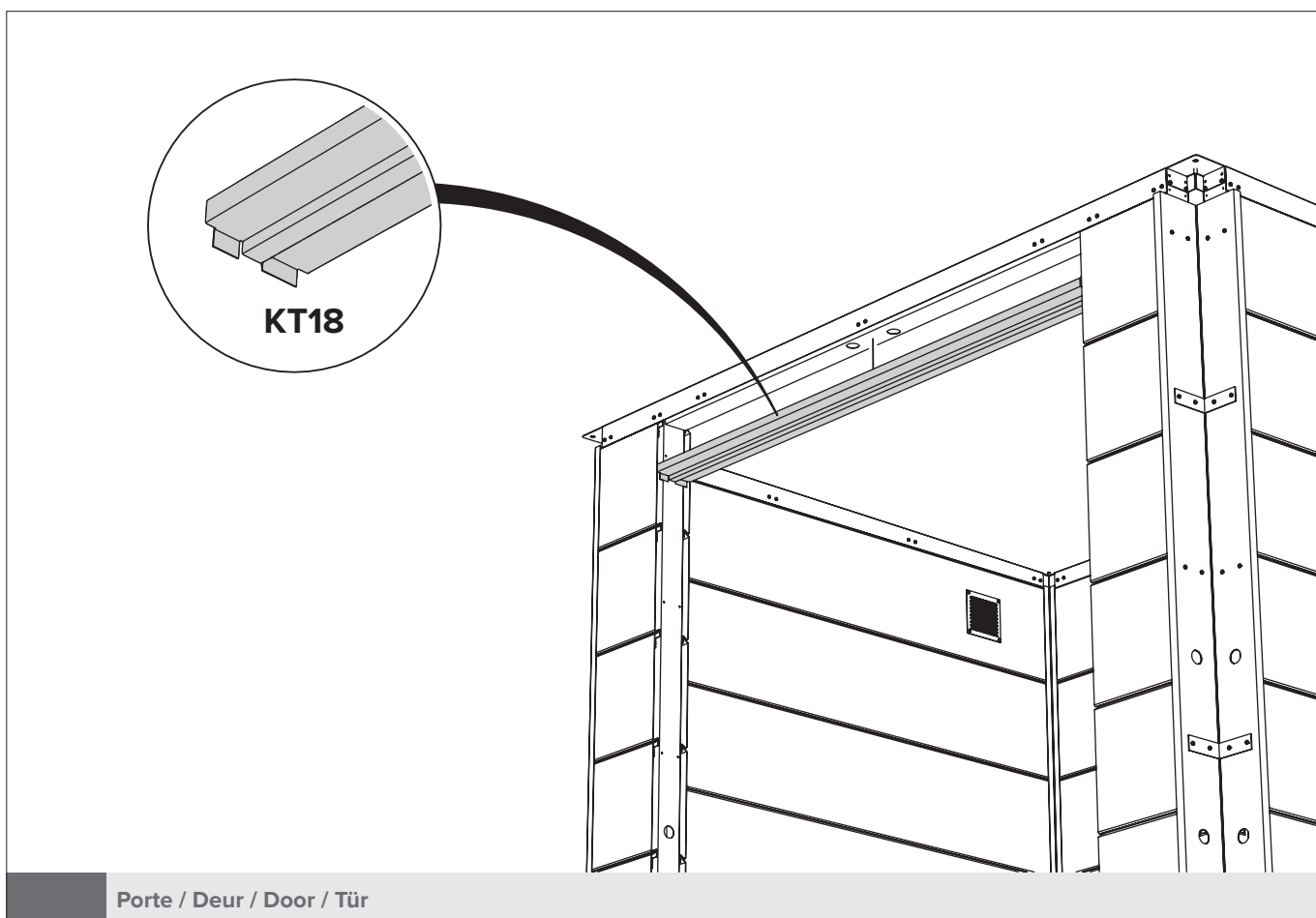
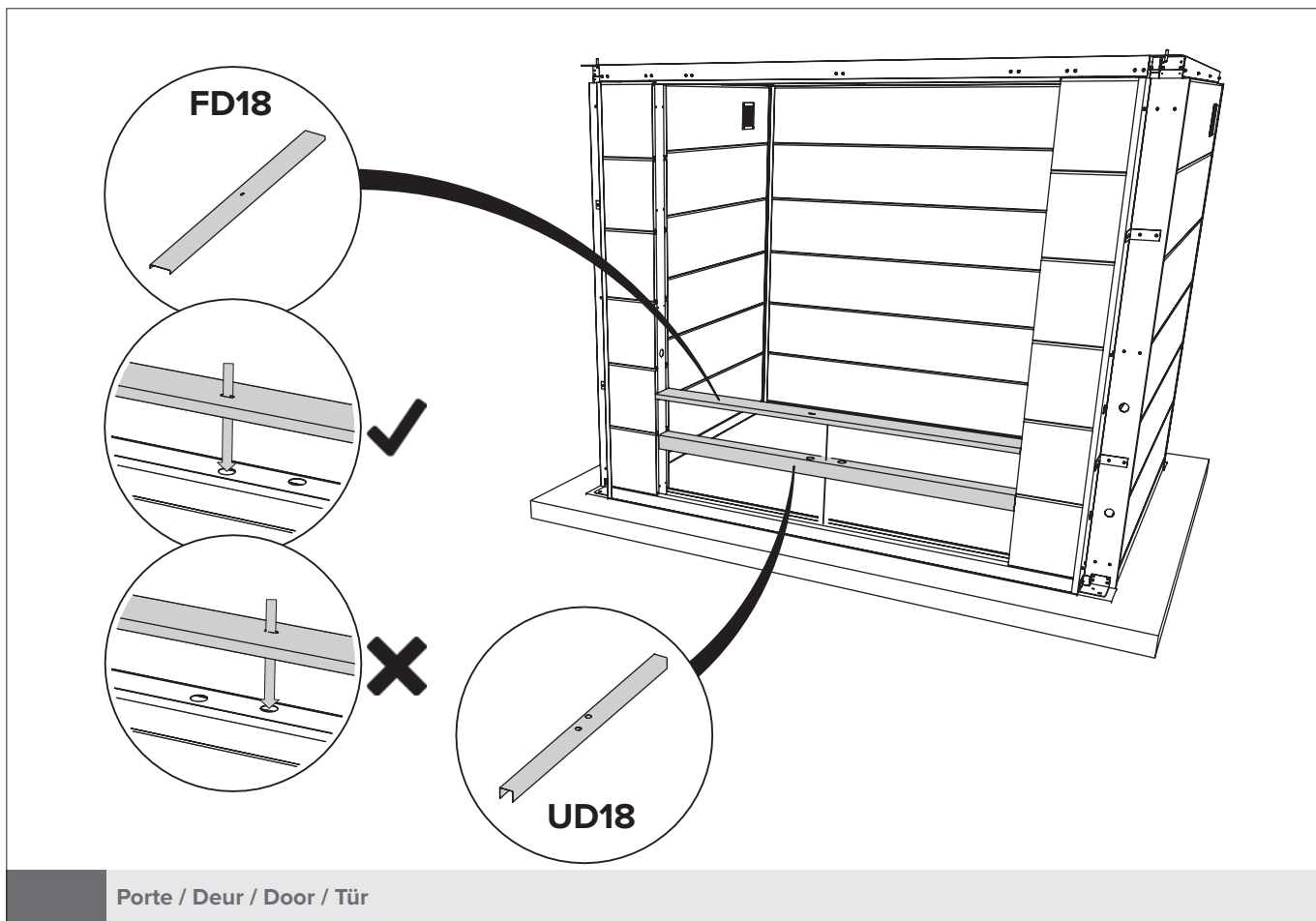

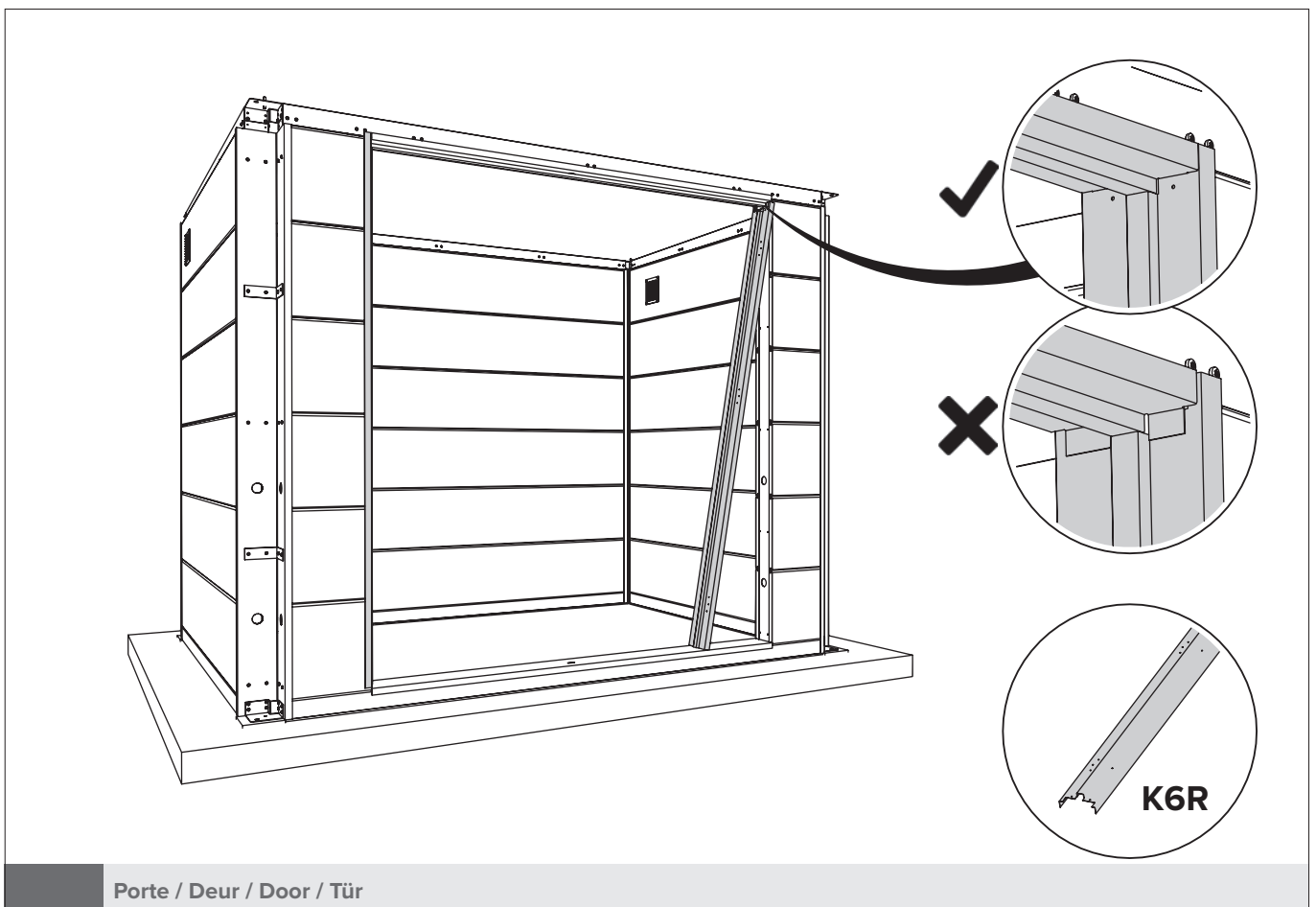
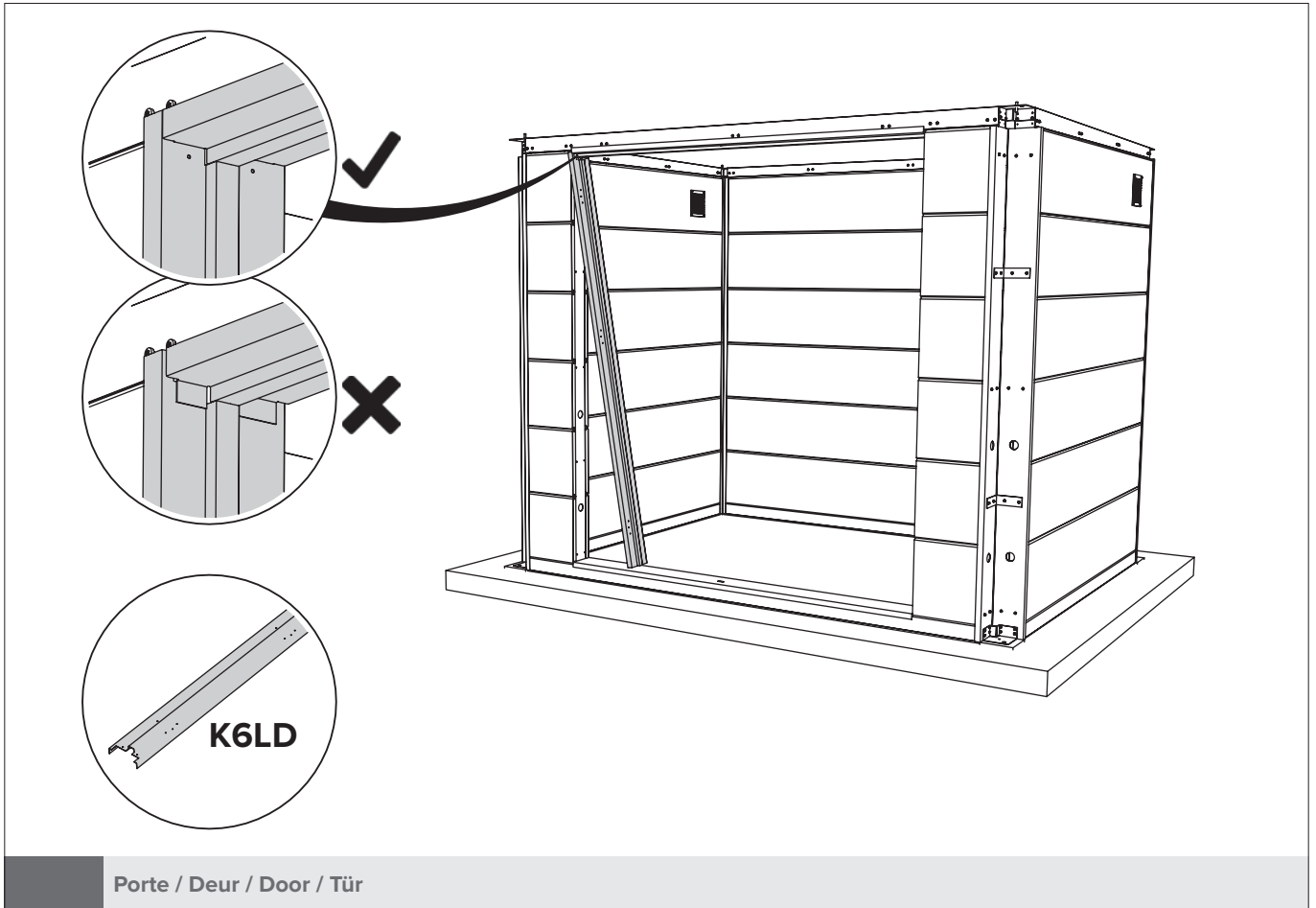

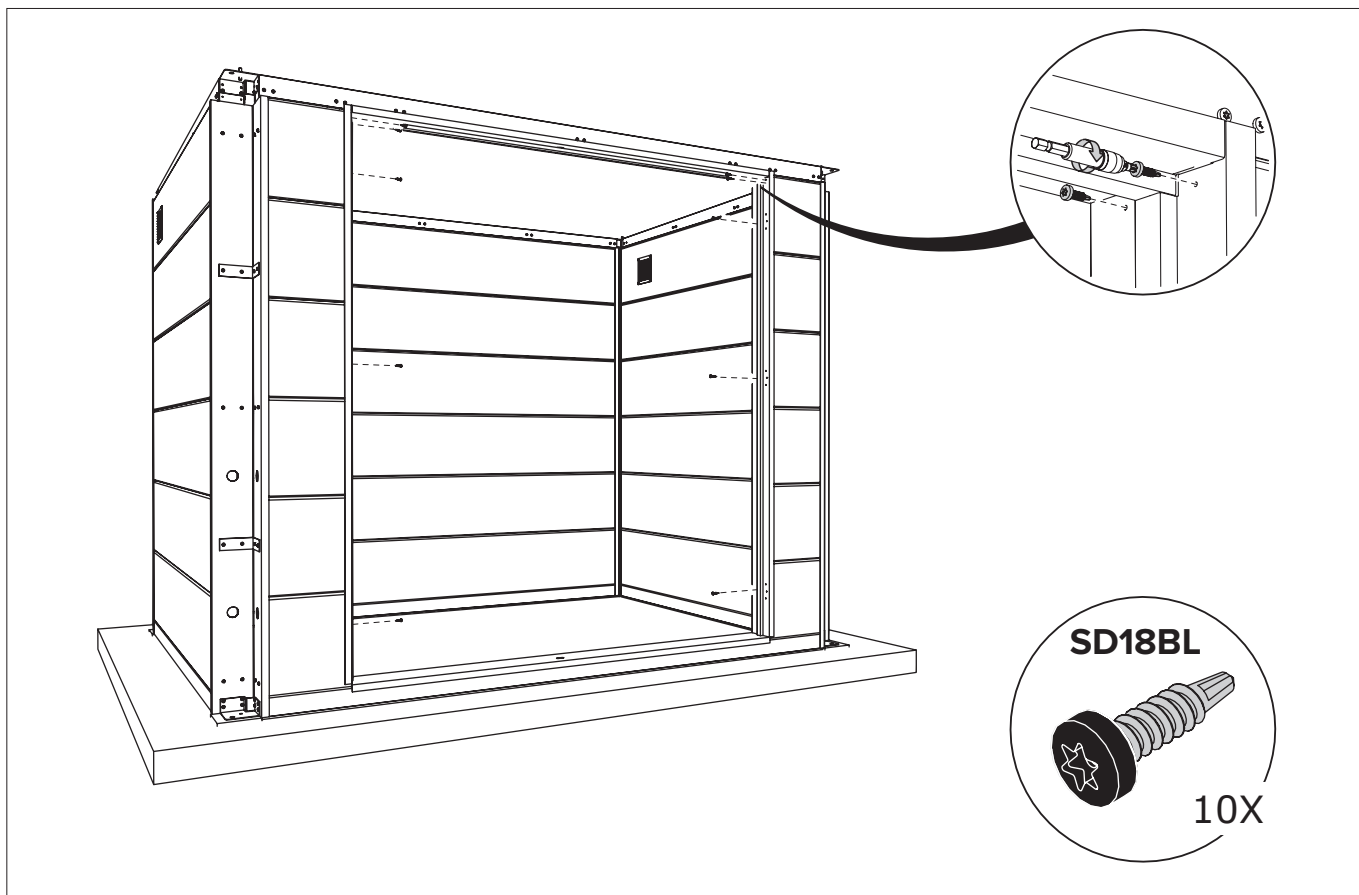

Porte / Deur / Door / Tür

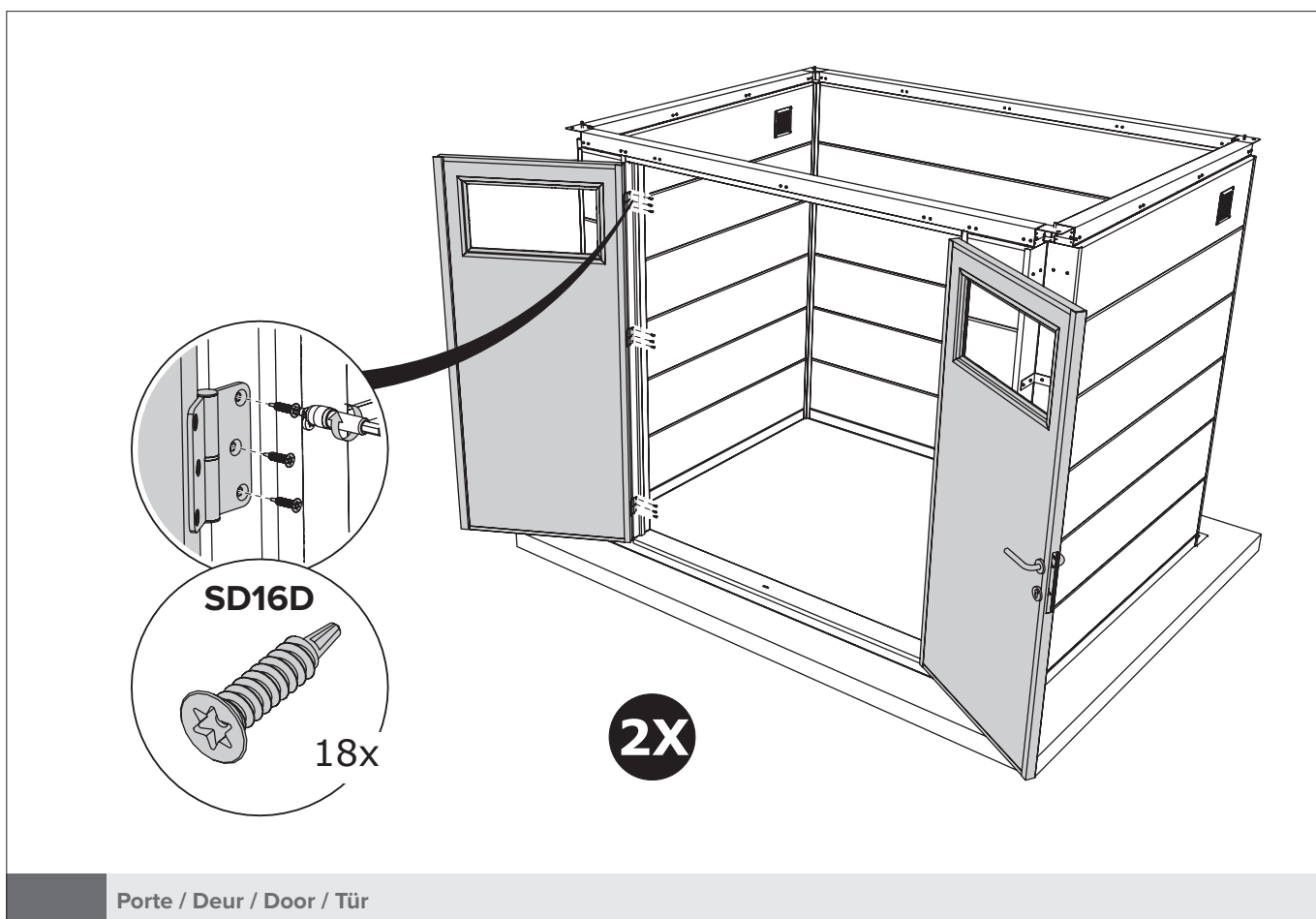

Porte / Deur / Door / Tür

revêtement intérieur  
binnenbekleding  
interior lining  
Innenverkleidung

IG = 2.090mm  
IK = 2.070mm

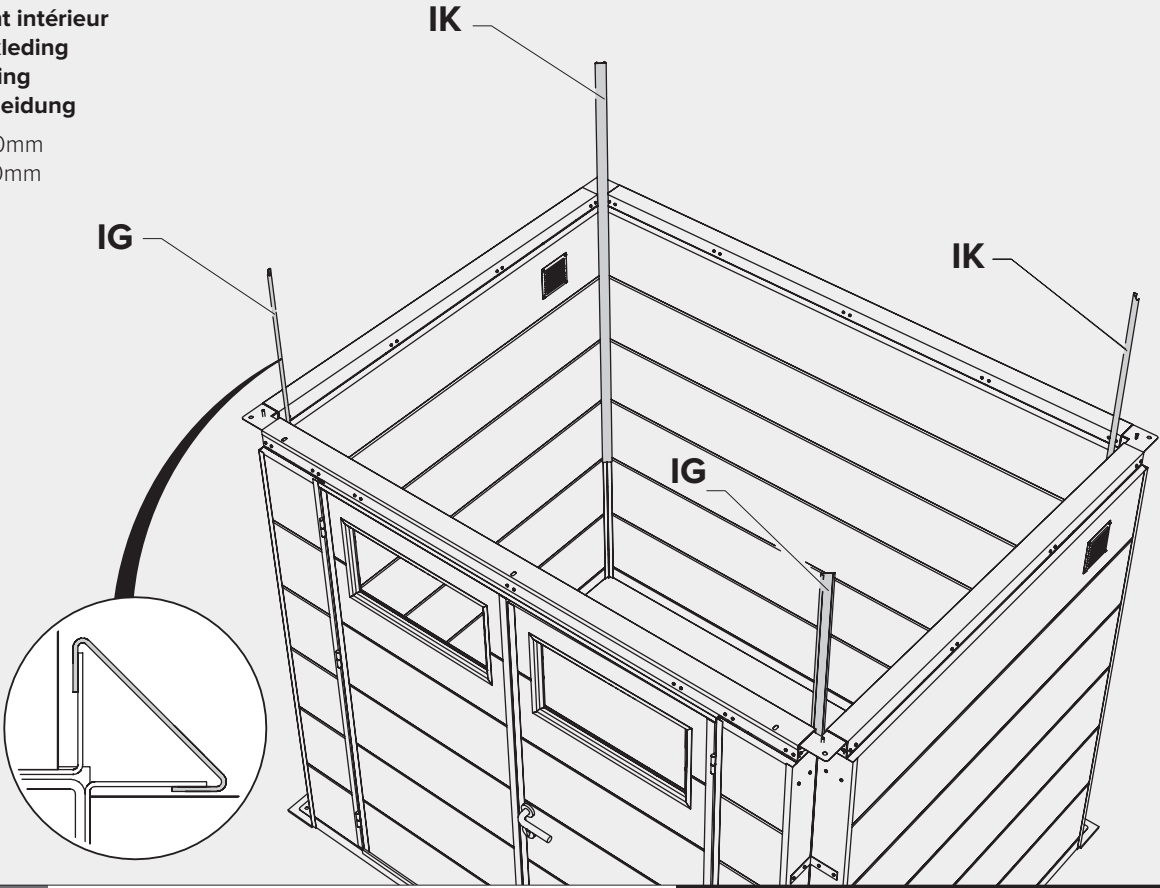

A + B + C + D Paroi / Wand / Wall / Wand

Option / Optie / Option / Option

revêtement intérieur  
binnenbekleding  
interior lining  
Innenverkleidung

X21D

X27C

X27A

X21B

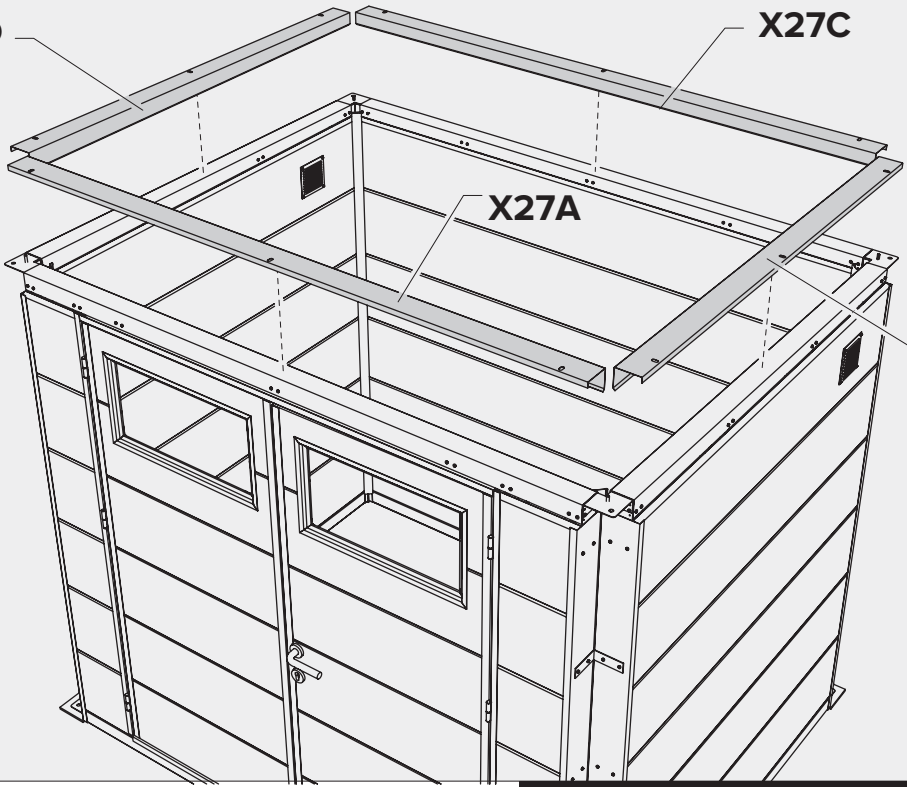

A + B + C + D Paroi / Wand / Wall / Wand

Option / Optie / Option / Option

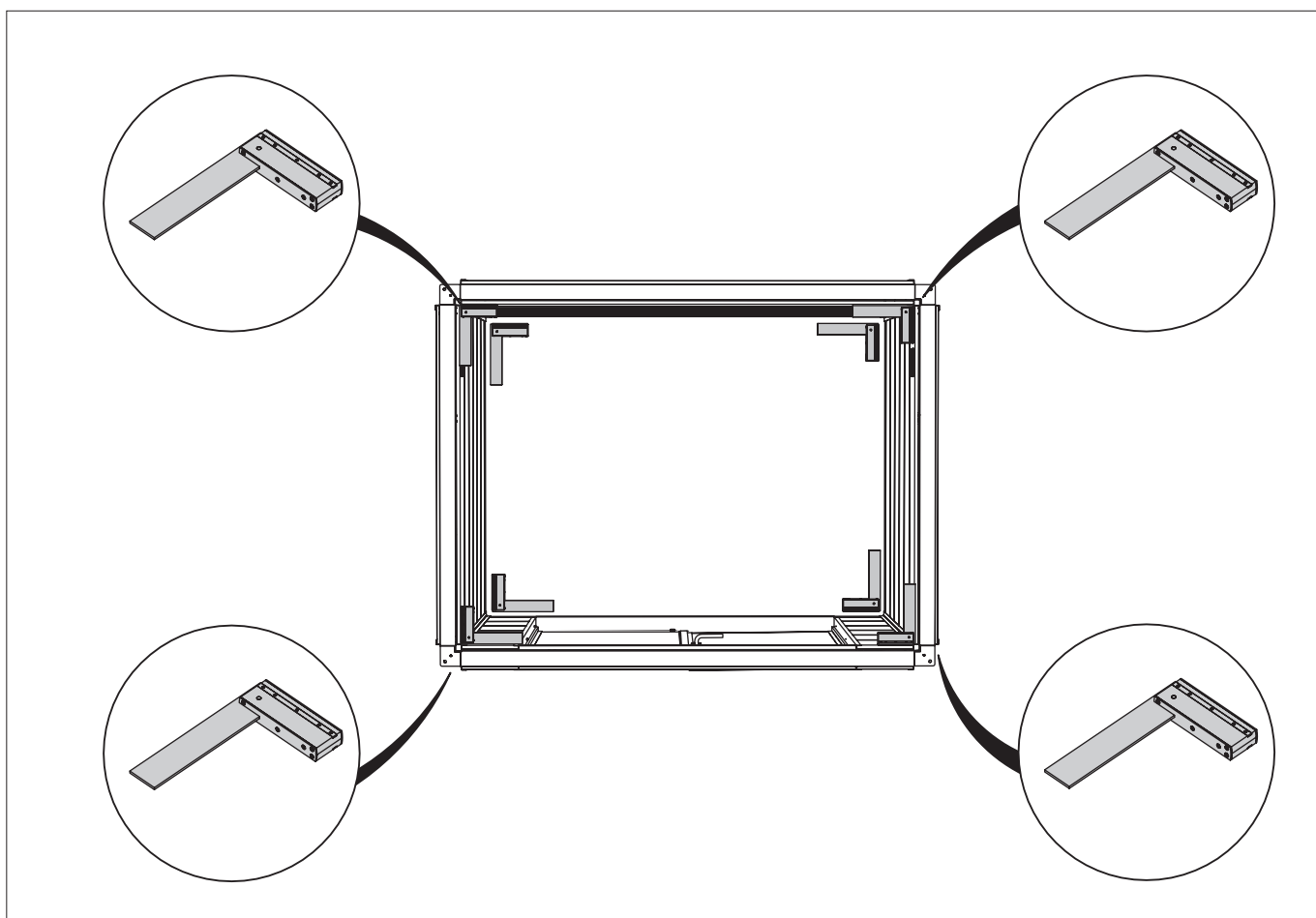
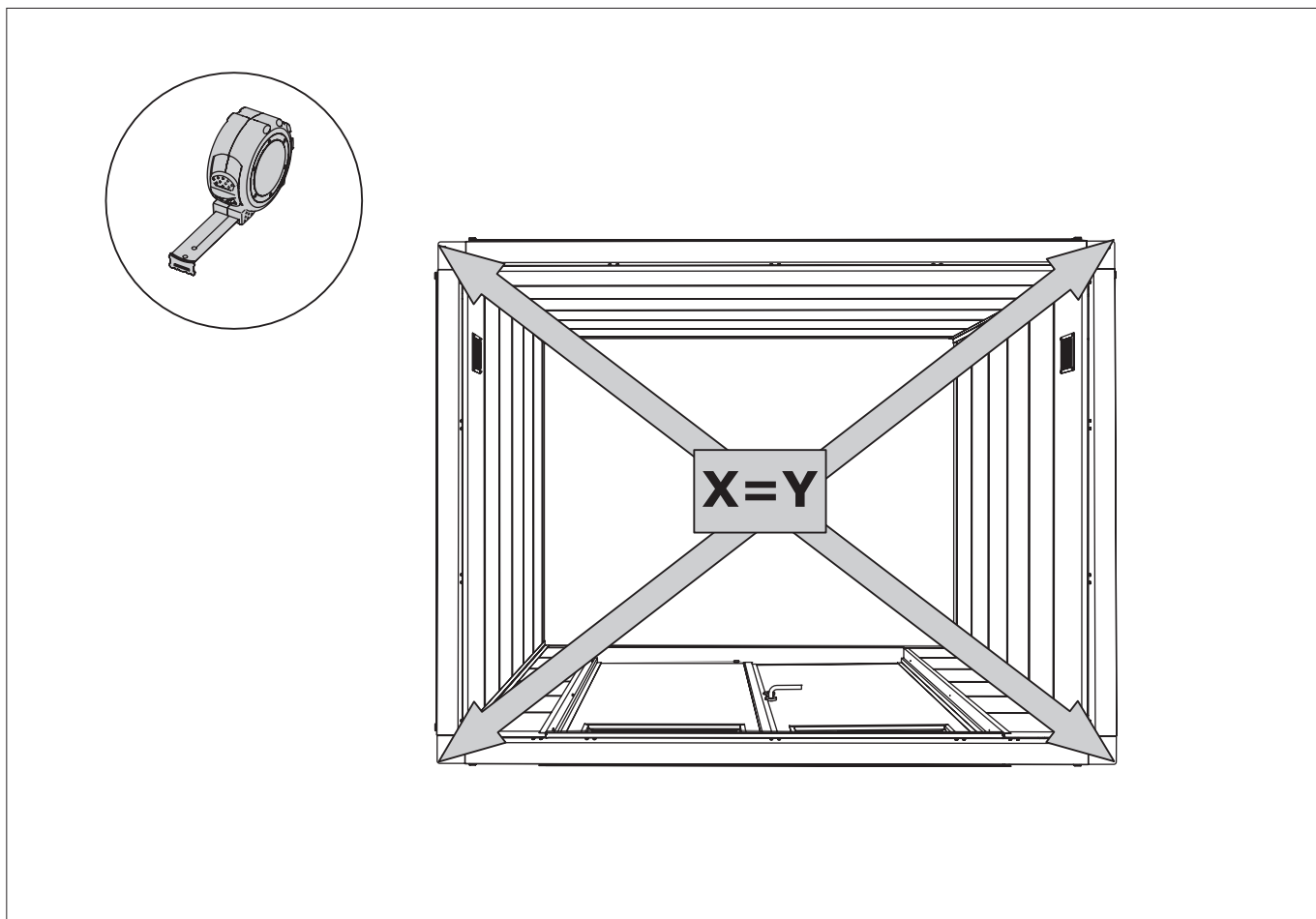



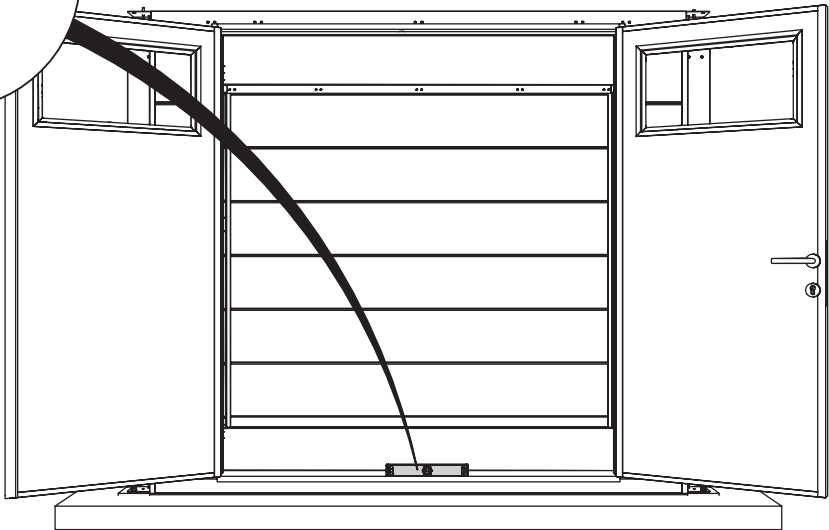
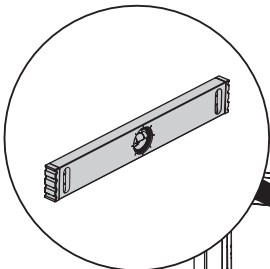
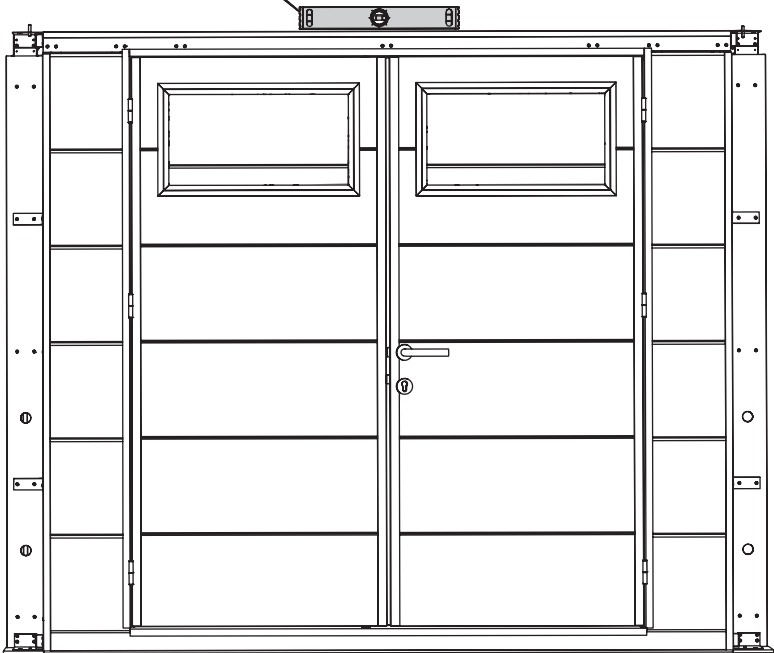
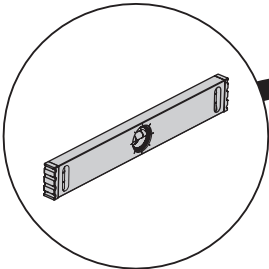

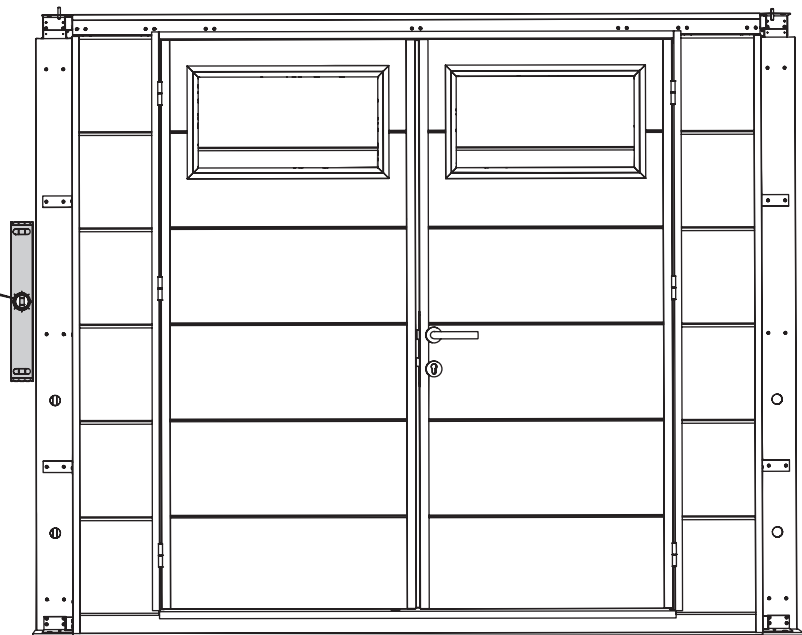
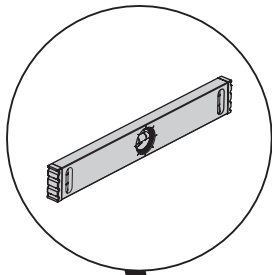

Retirer la bande / Tape verwijderen / Remove tape / Klebeband entfernen

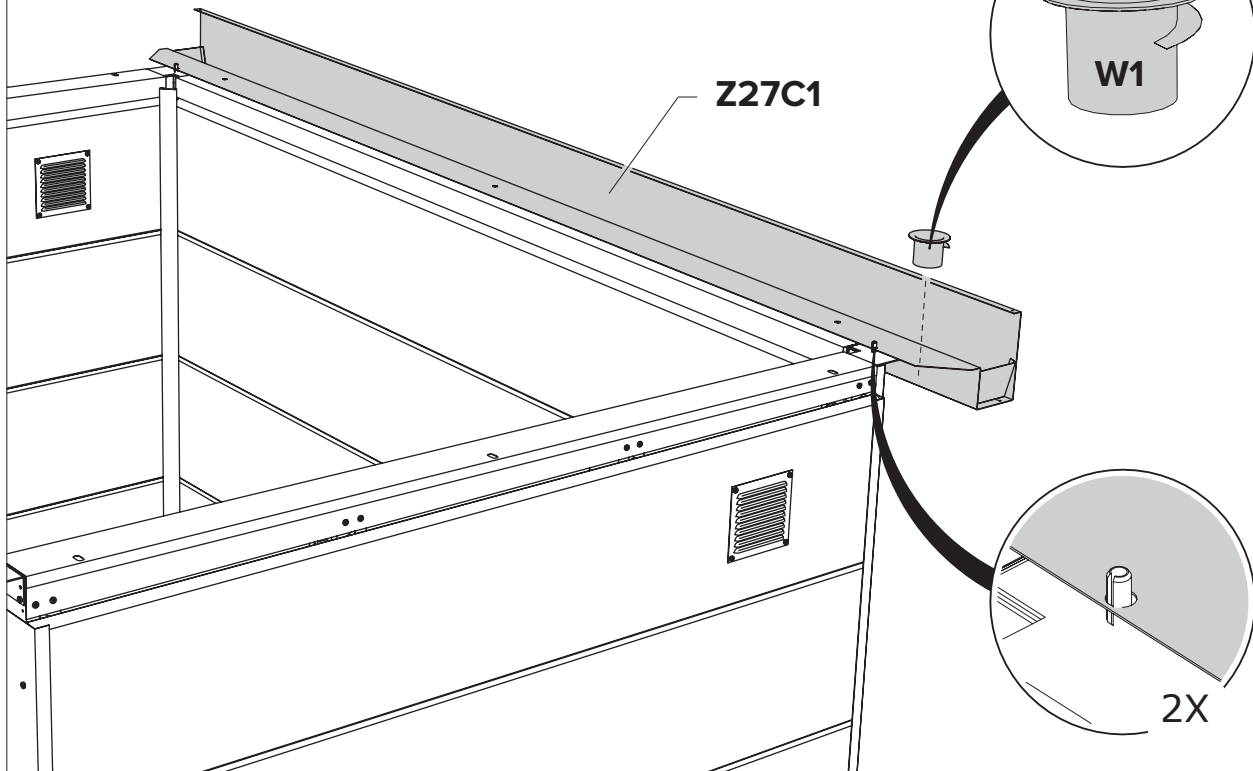

Toit / Dak / Roof / Dach

Retirer le film / Verwijder folie / Remove foil / Folie entfernen

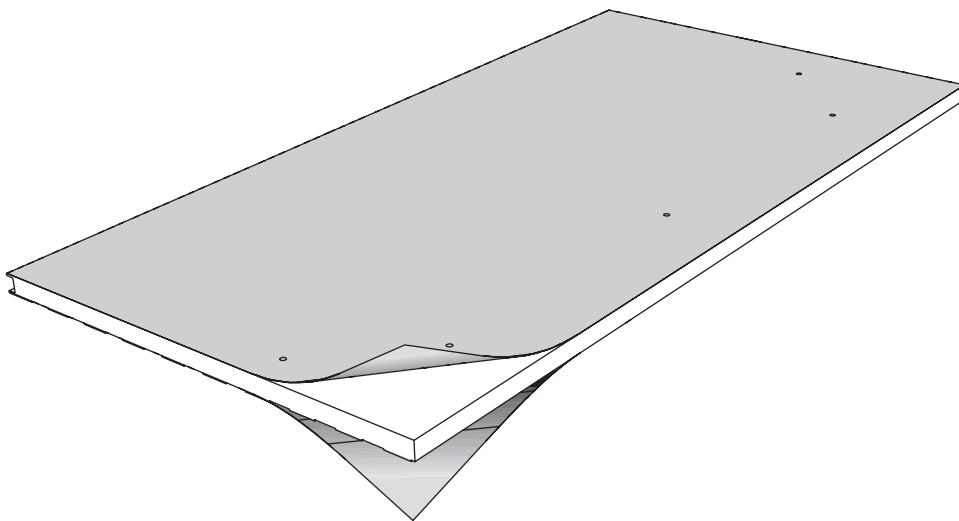

Toit / Dak / Roof / Dach

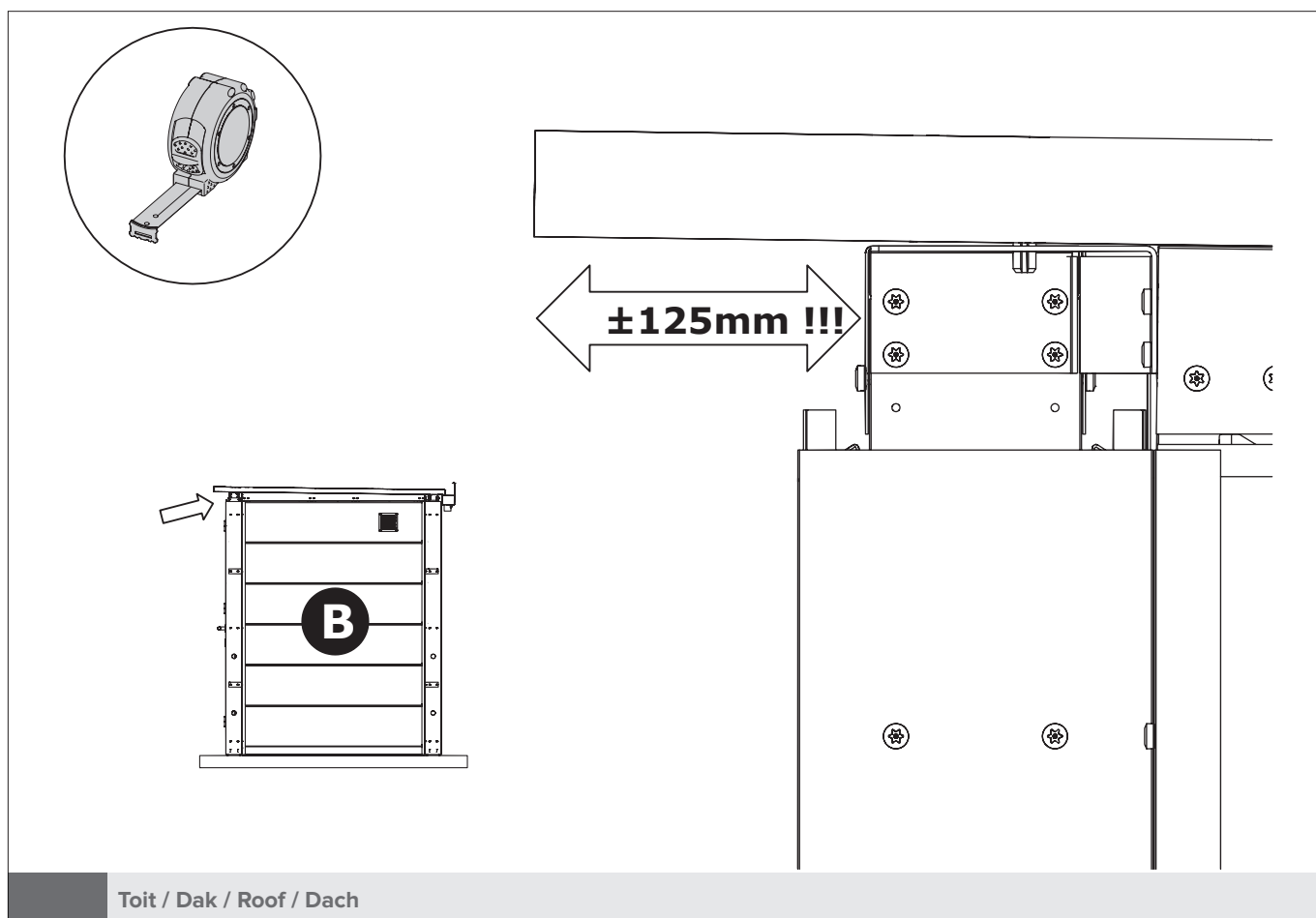
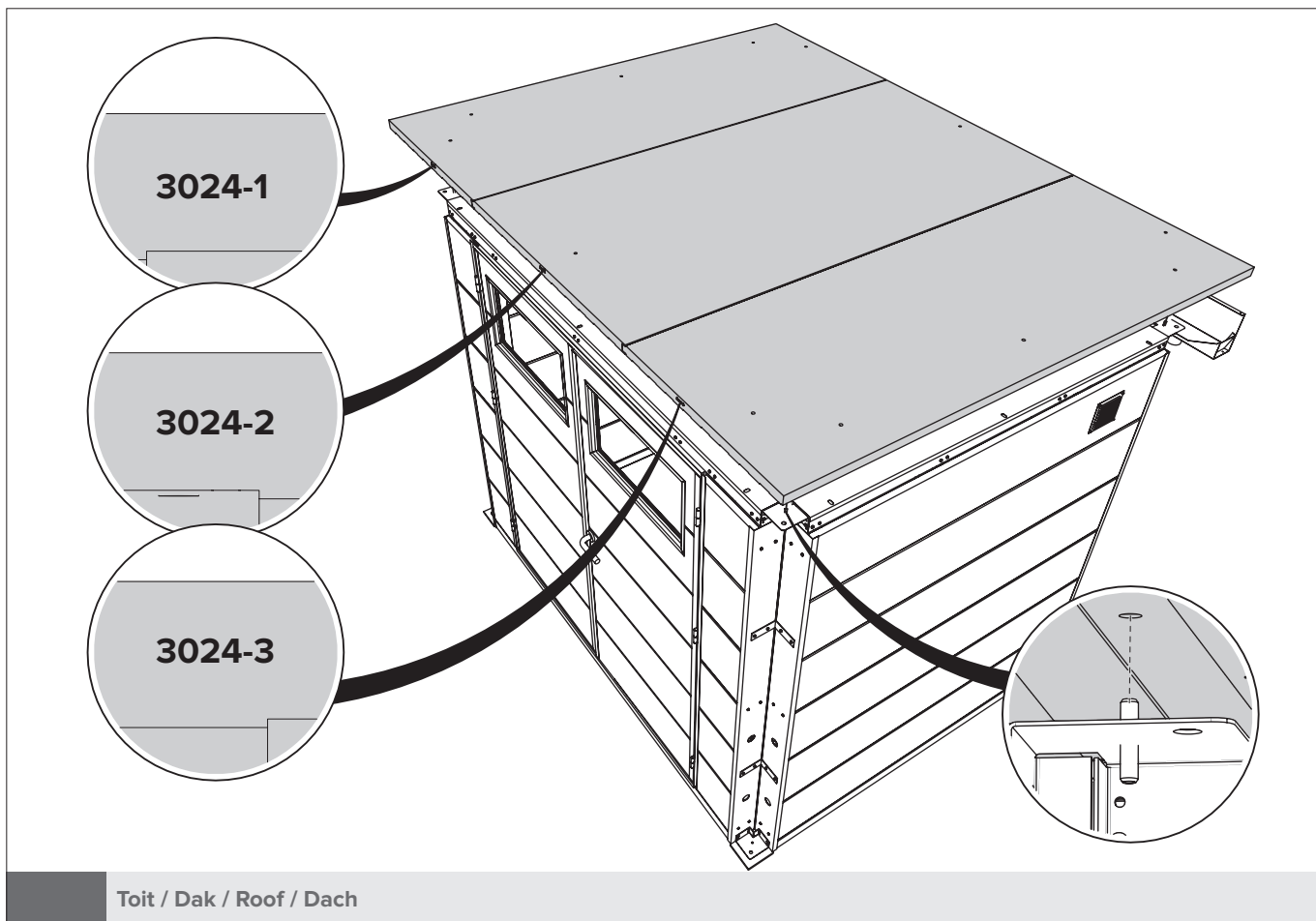

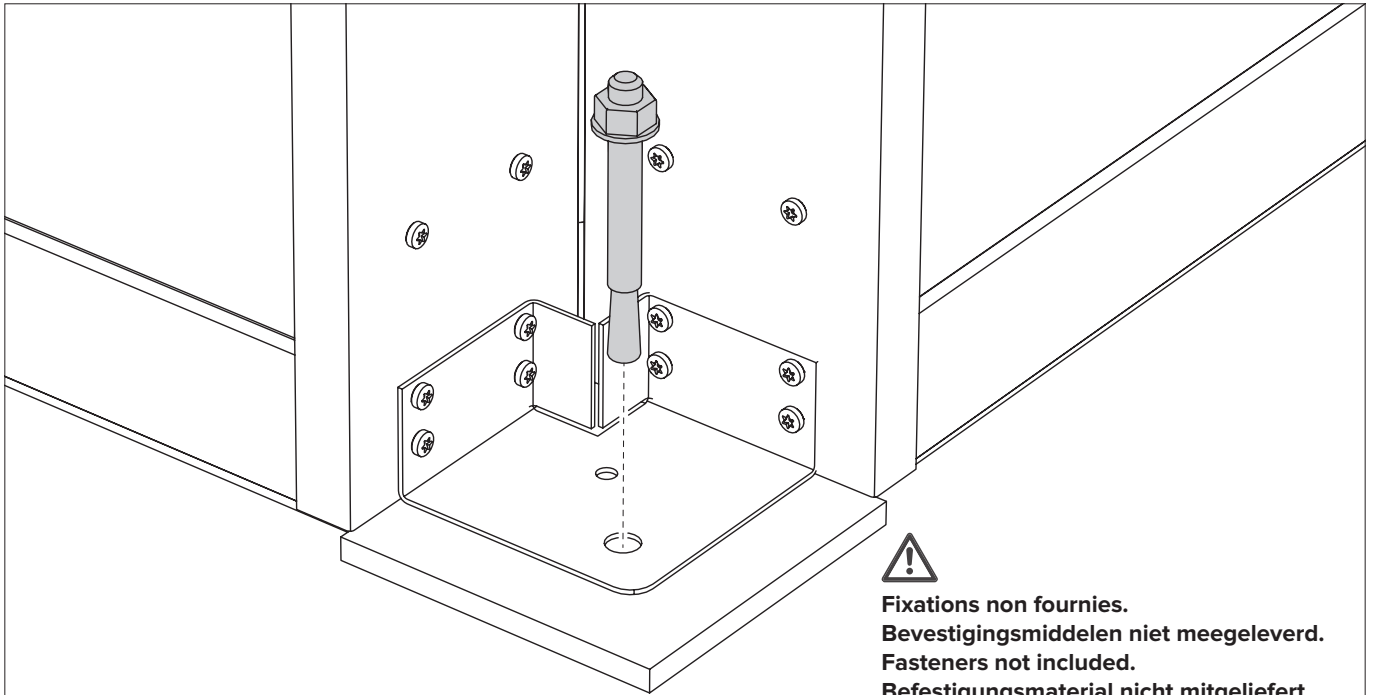

Exemple donné pour un sous-sol en béton. Fixer l'abri de jardin dans les règles de l'art.  
Voorbeeld is voor beton-ondergrond. Tuinhuisje fixeren volgens de regels van de kunst.  
Example is for concrete substrate. Fix the garden shed in accordance with good practise.  
Beispiel ist für Betonuntergrund. Fachgerechte Befestigung des Gartenhäuschens.

**Ancrage / Verankering / Anchoring / Verankerung**

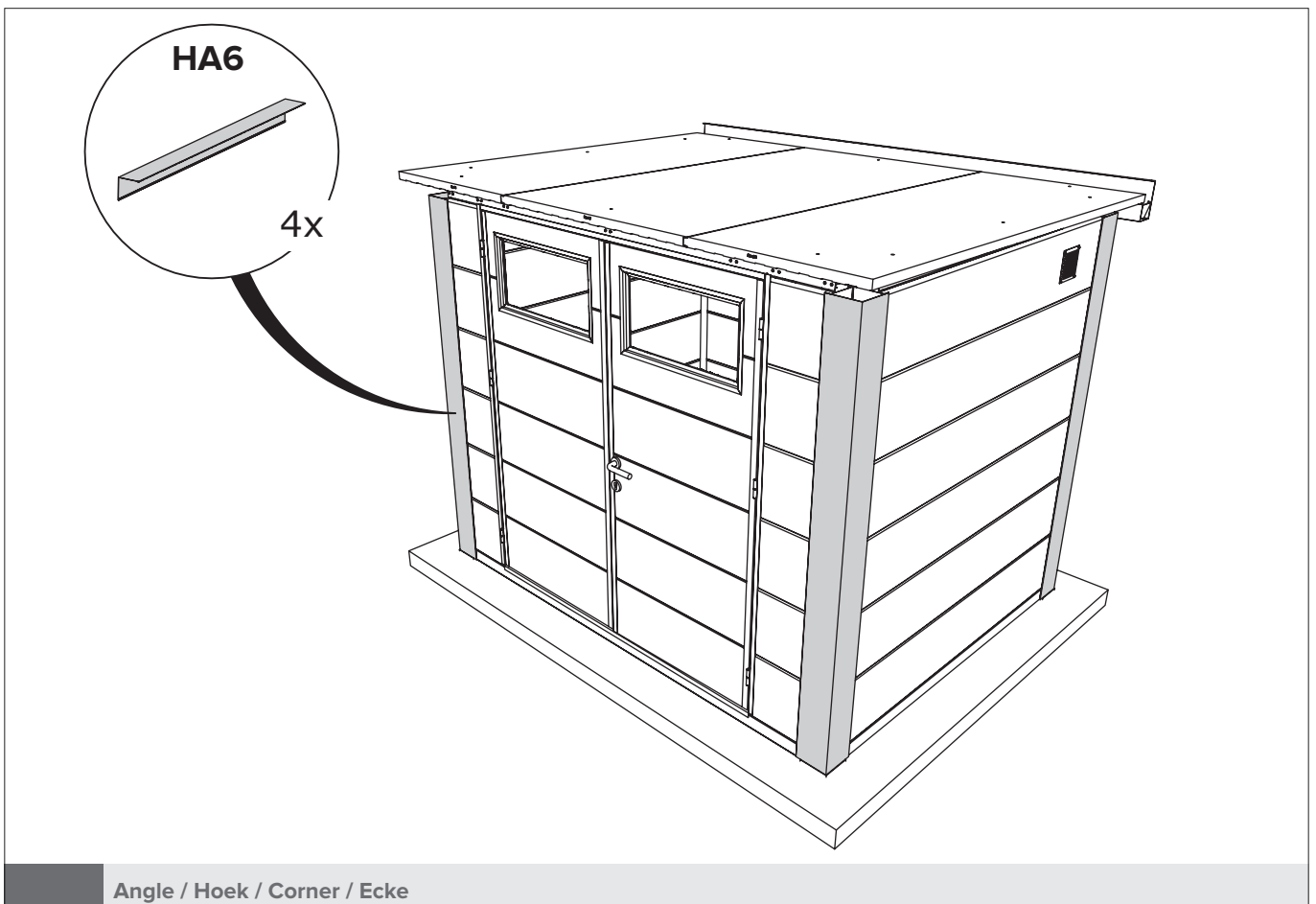

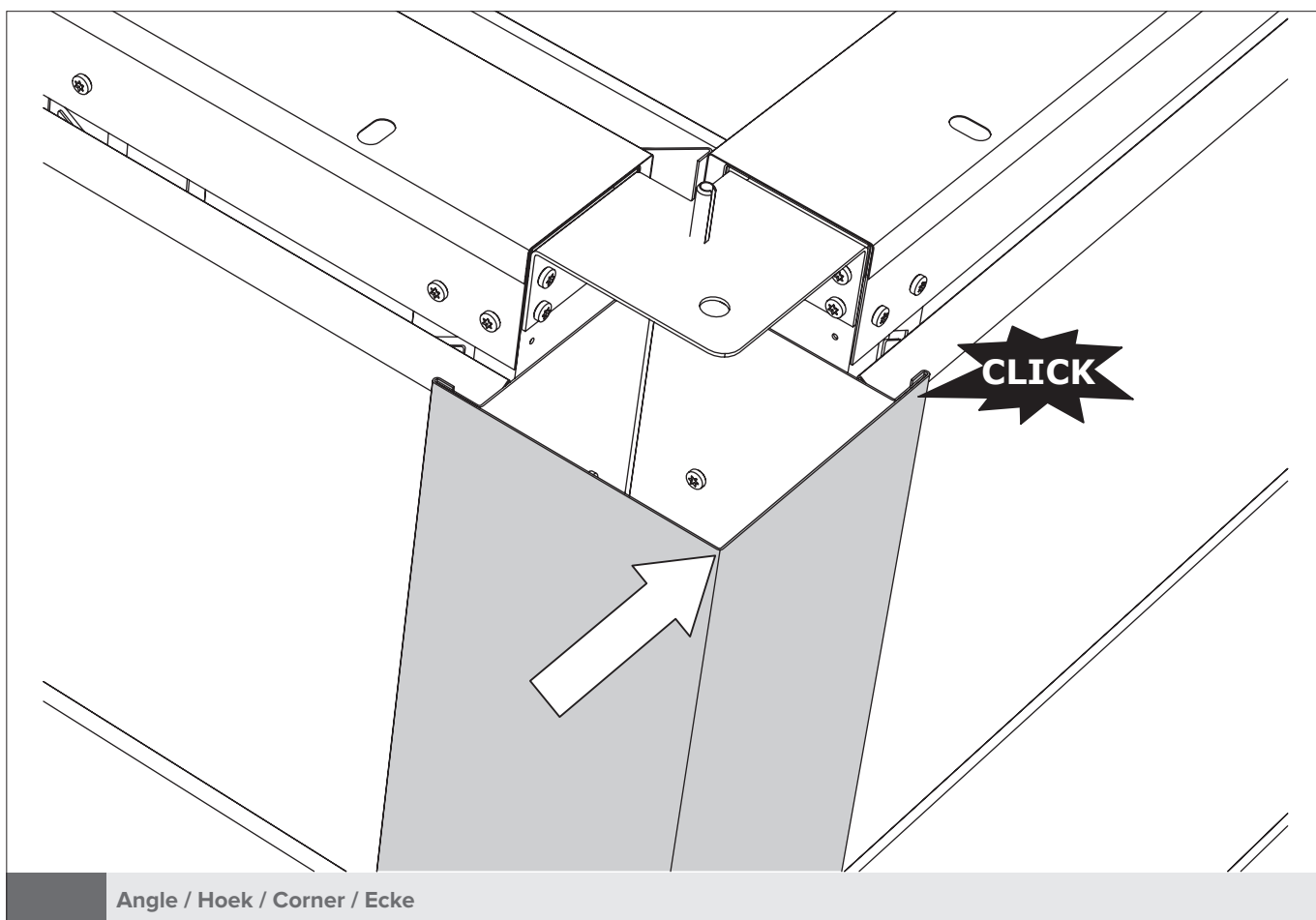
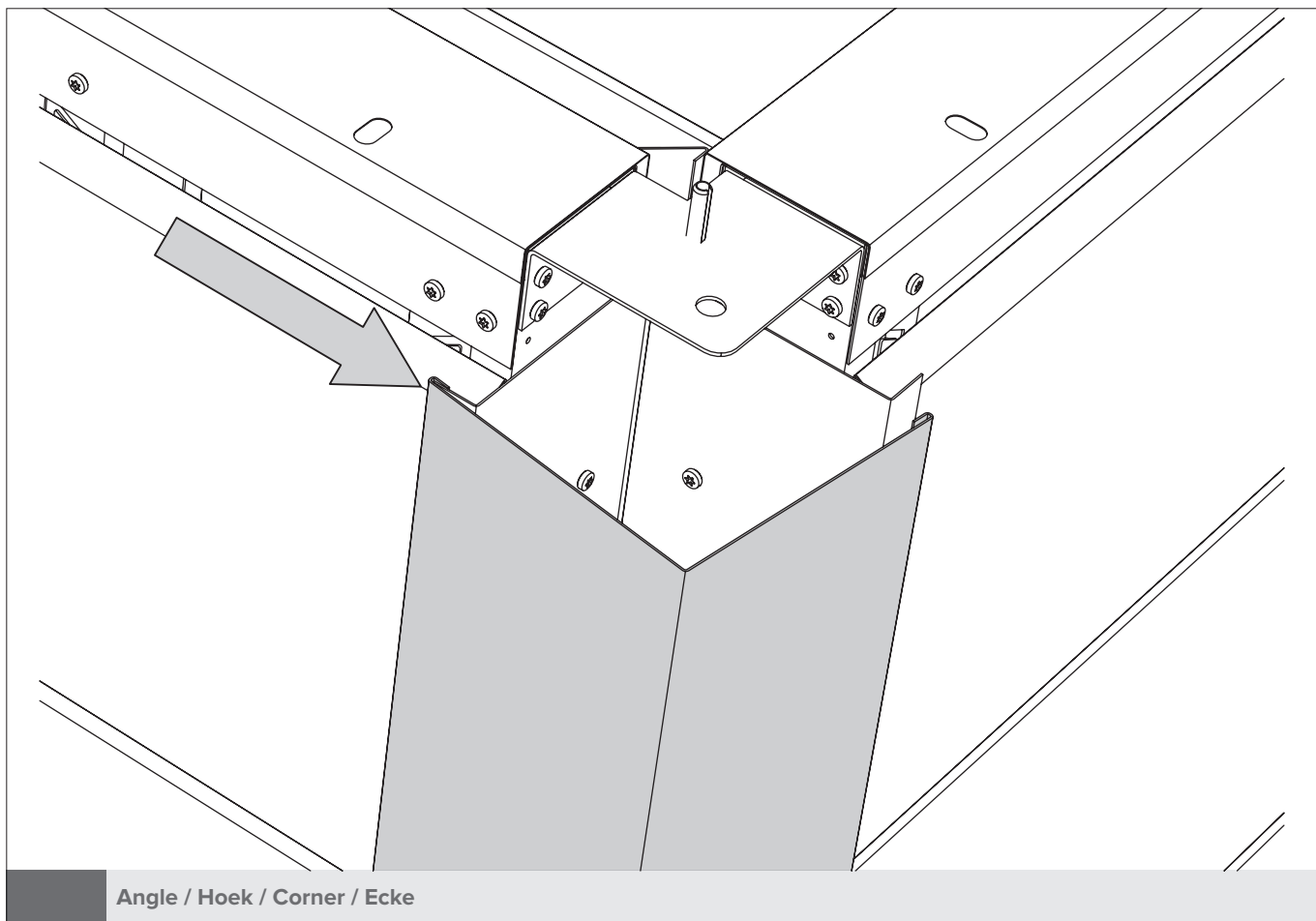

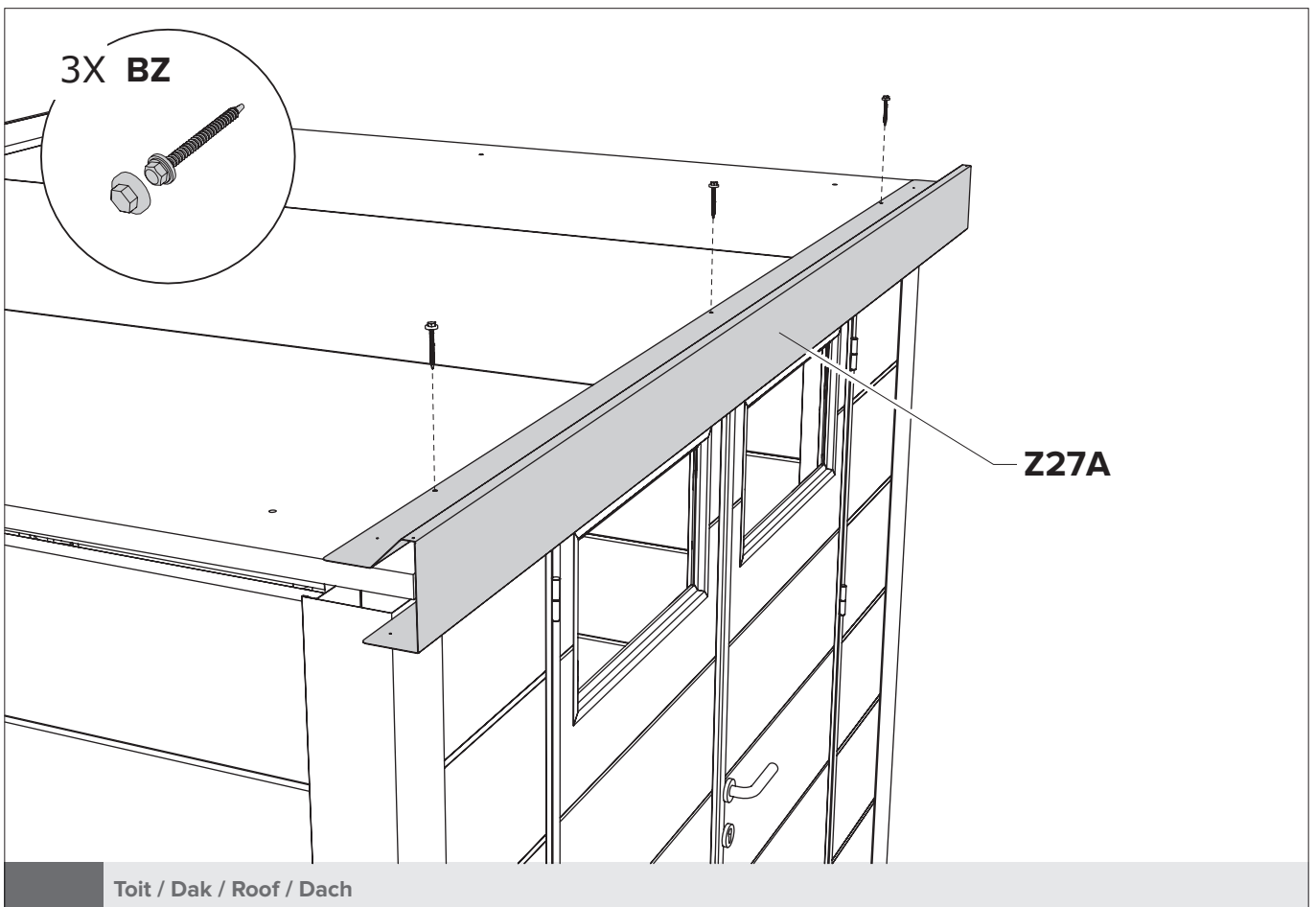
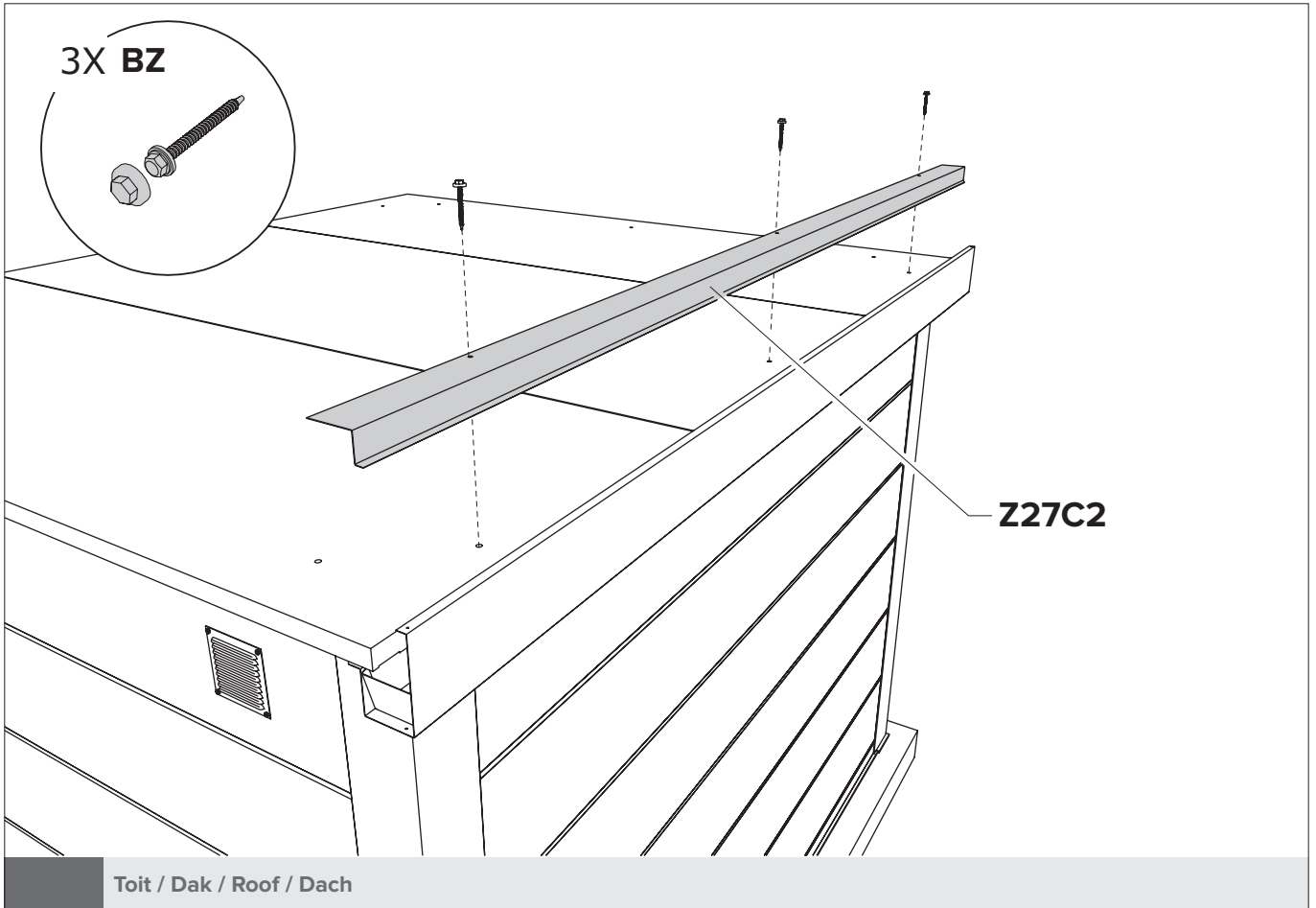

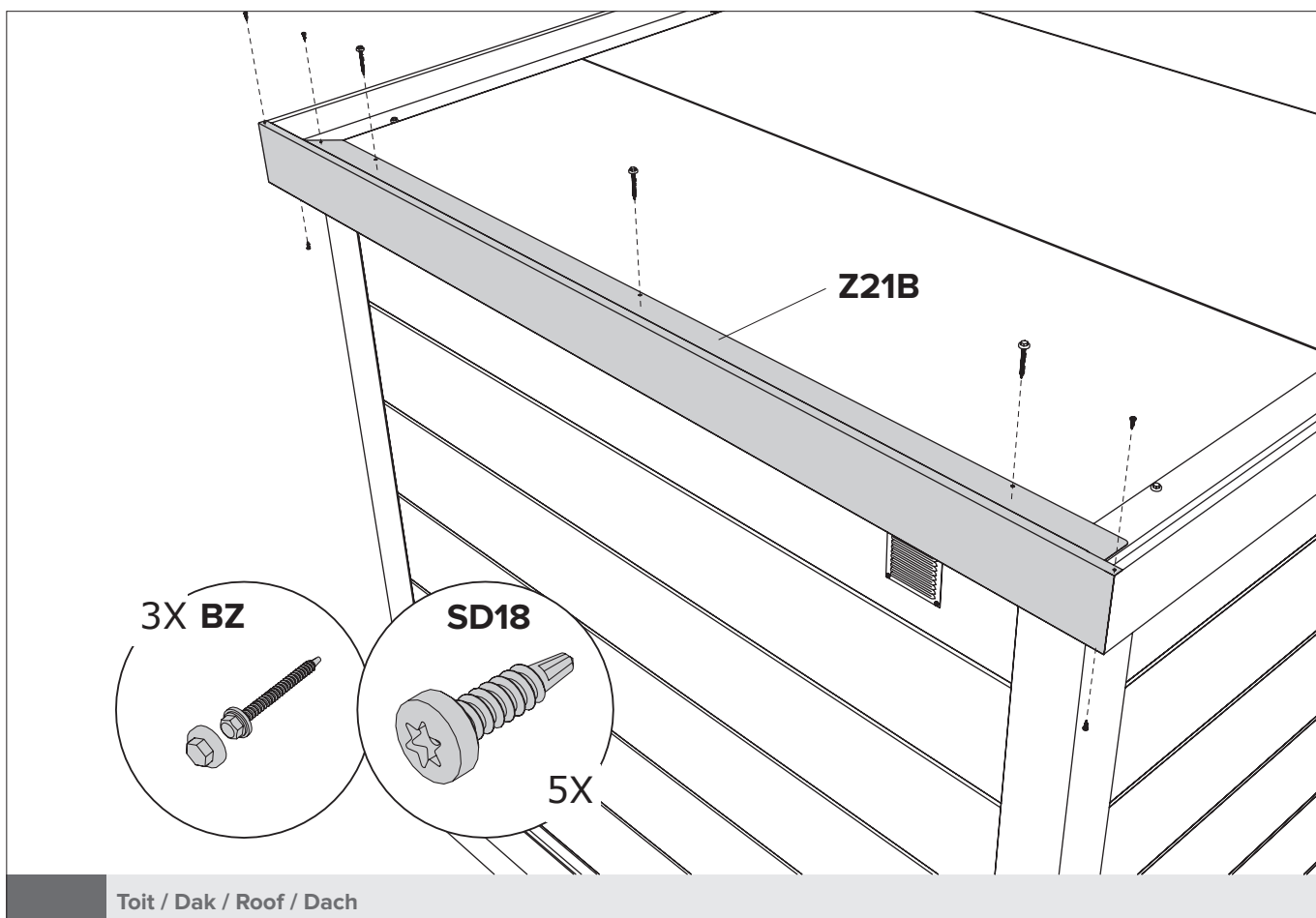
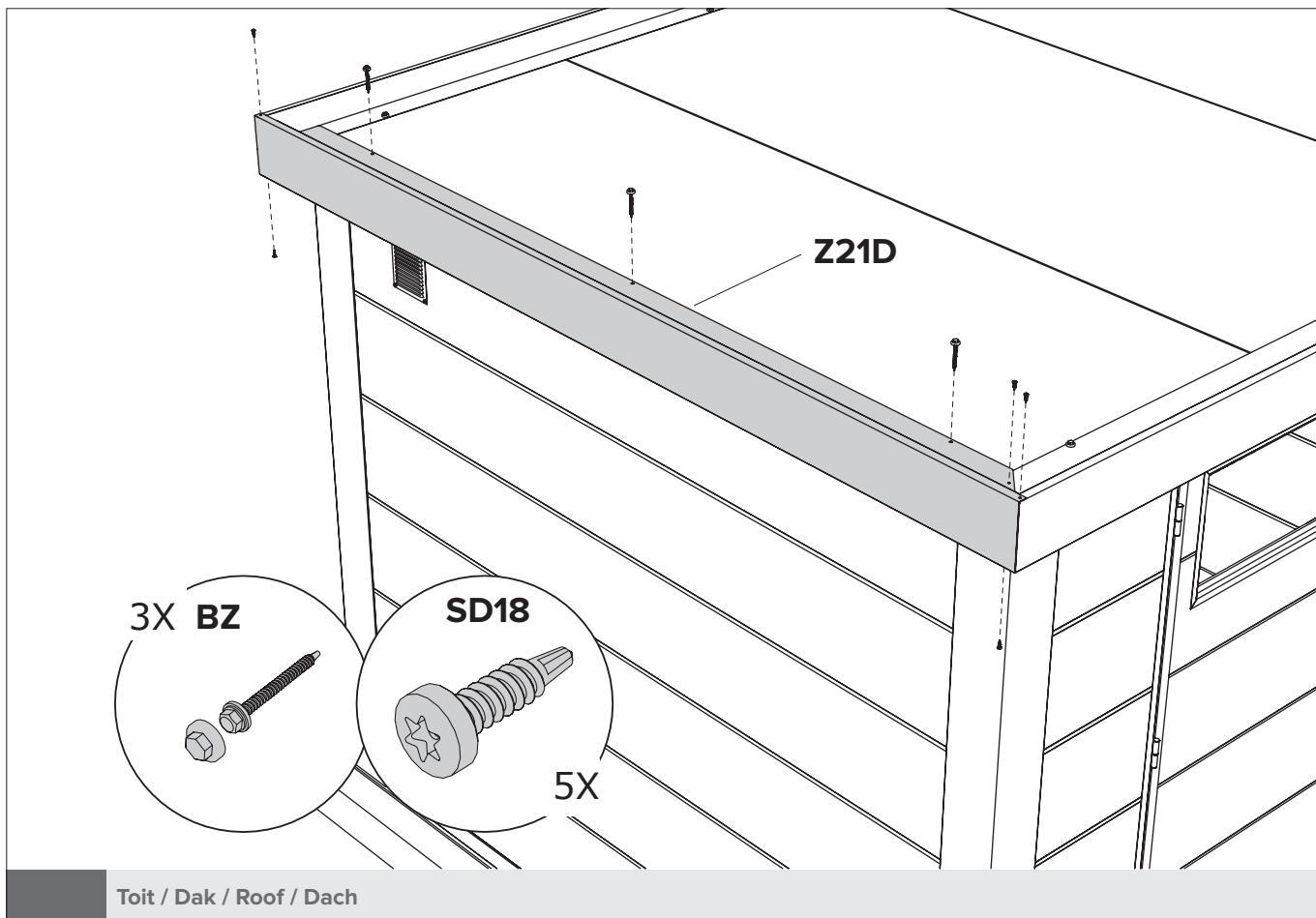



**Préparation du ruban auto-adhésif:**

1. Bien nettoyer la surface afin qu'il n'y ai ni poussière, ni humidité.
2. Chauffer la surface dans le cas d'une température extérieure  $<10^{\circ}\text{C}$ .

**Vorbereitung zelfklevende tape:**

1. Oppervlak stof- en vochtvrij maken”.
2. Bij  $<10^{\circ}\text{C}$  is opwarmen ondergrond d.m.v. warmtepistool (Föhn) vereist”.

**Preparation of self-adhesive tape:**

1. Make the surface dust-free and moisture-free.
2. Heat up the surface in case of  $<10^{\circ}\text{C}$  outside temperature.

**Vorbereitung des Klebebandes:**

1. Machen Sie die Oberfläche staubfrei und feuchtigkeitsfrei.
2. Erwärmen Sie Oberfläche bei einer Außentemperatur von  $<10^{\circ}\text{C}$ .

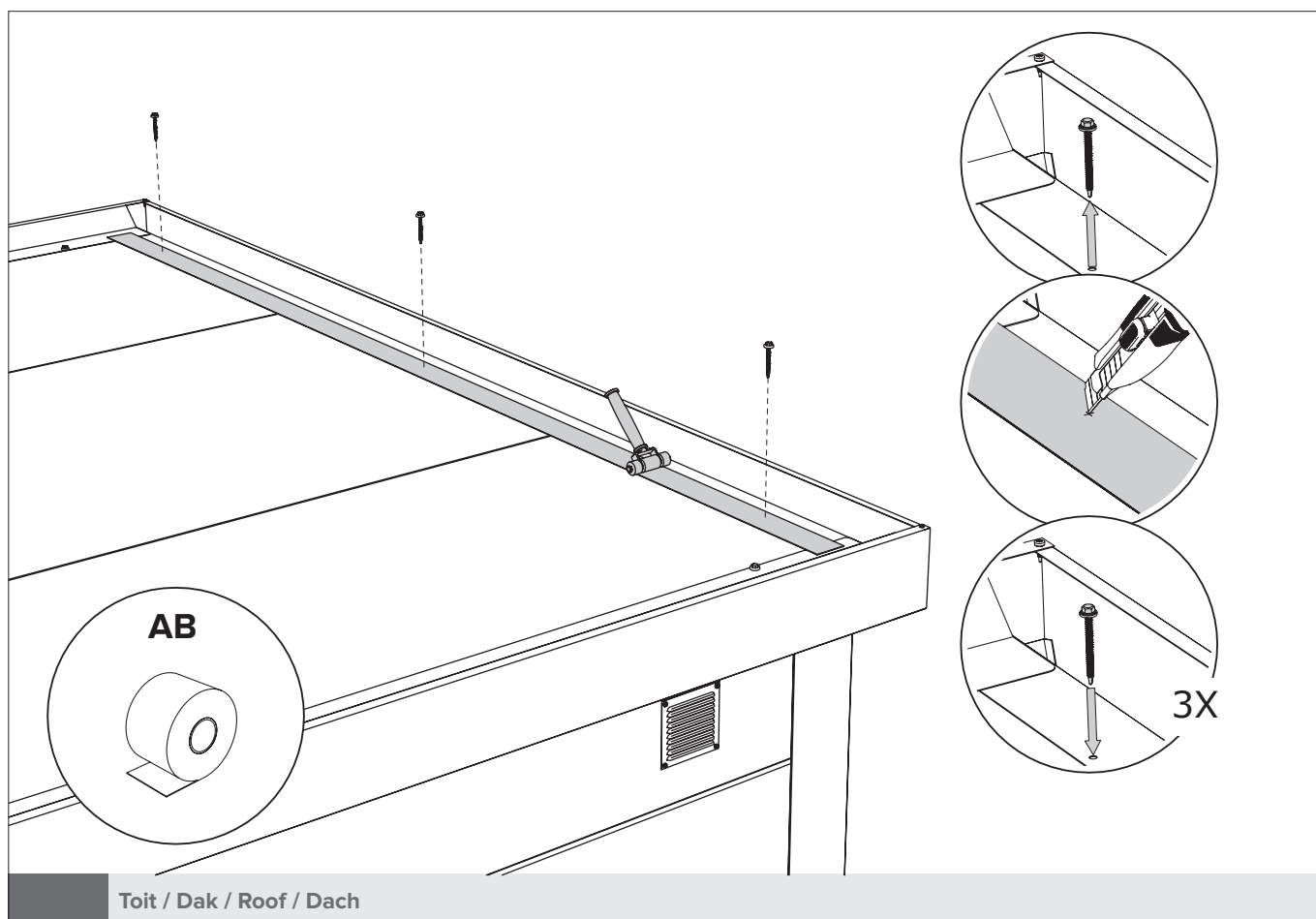

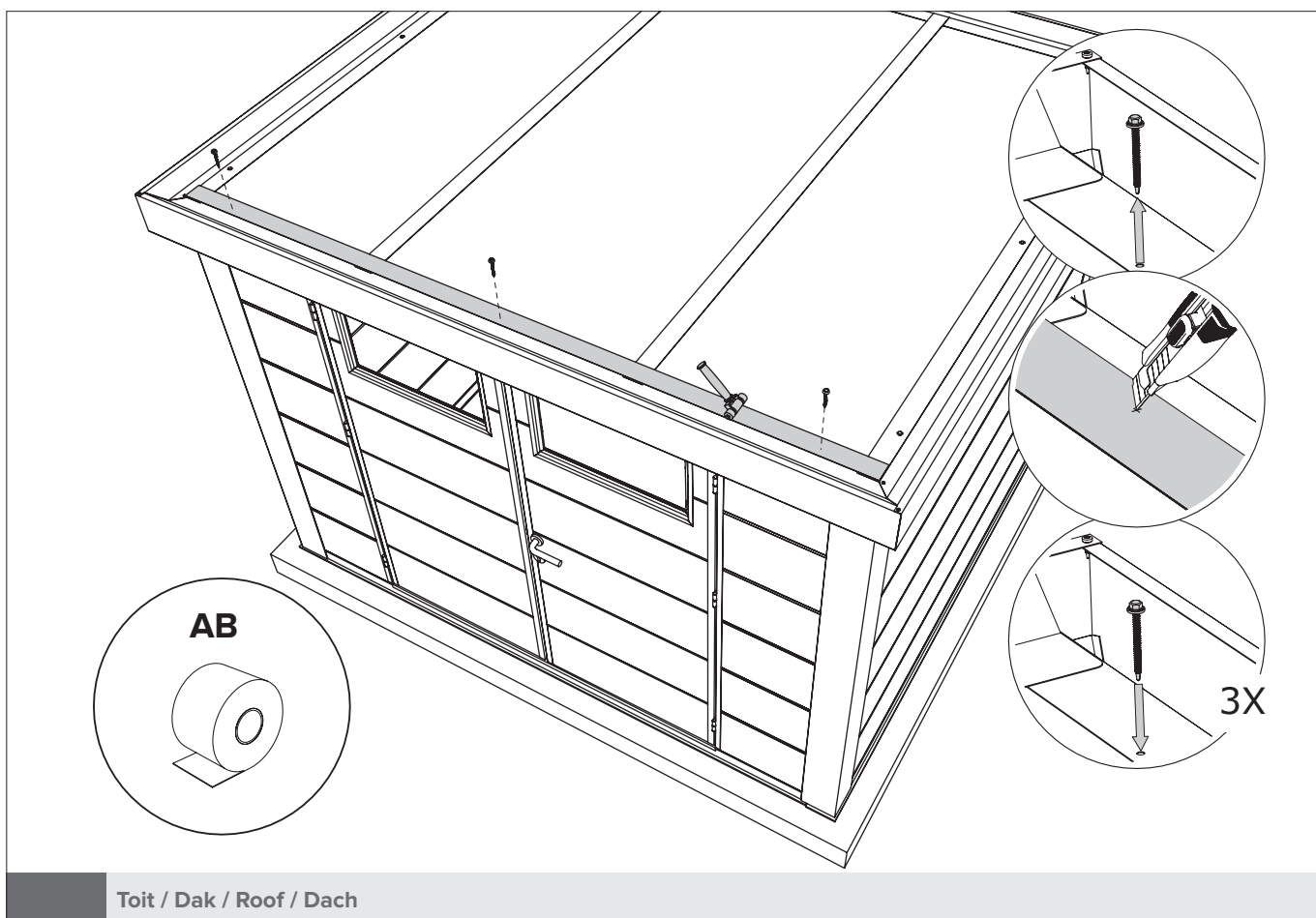
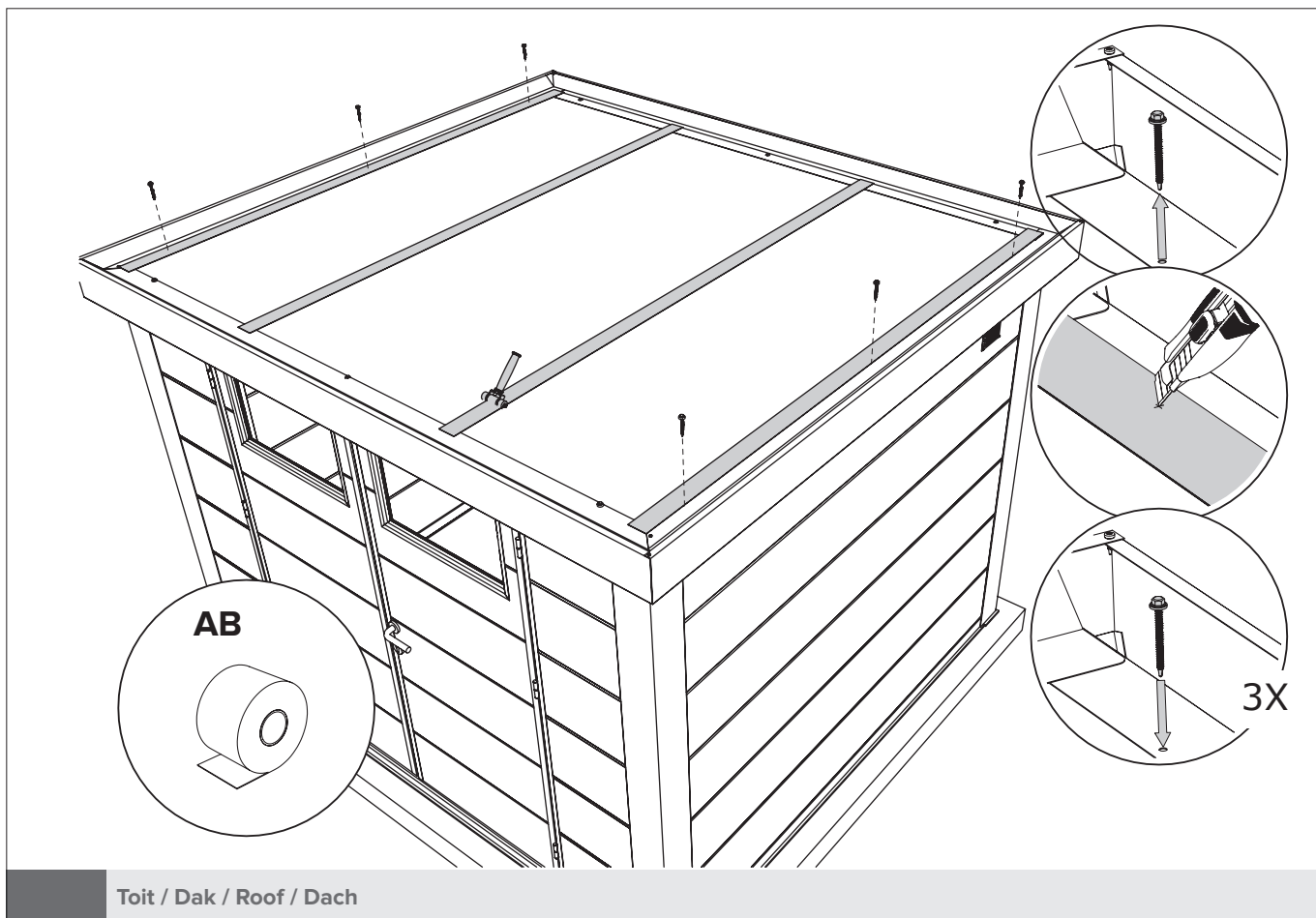

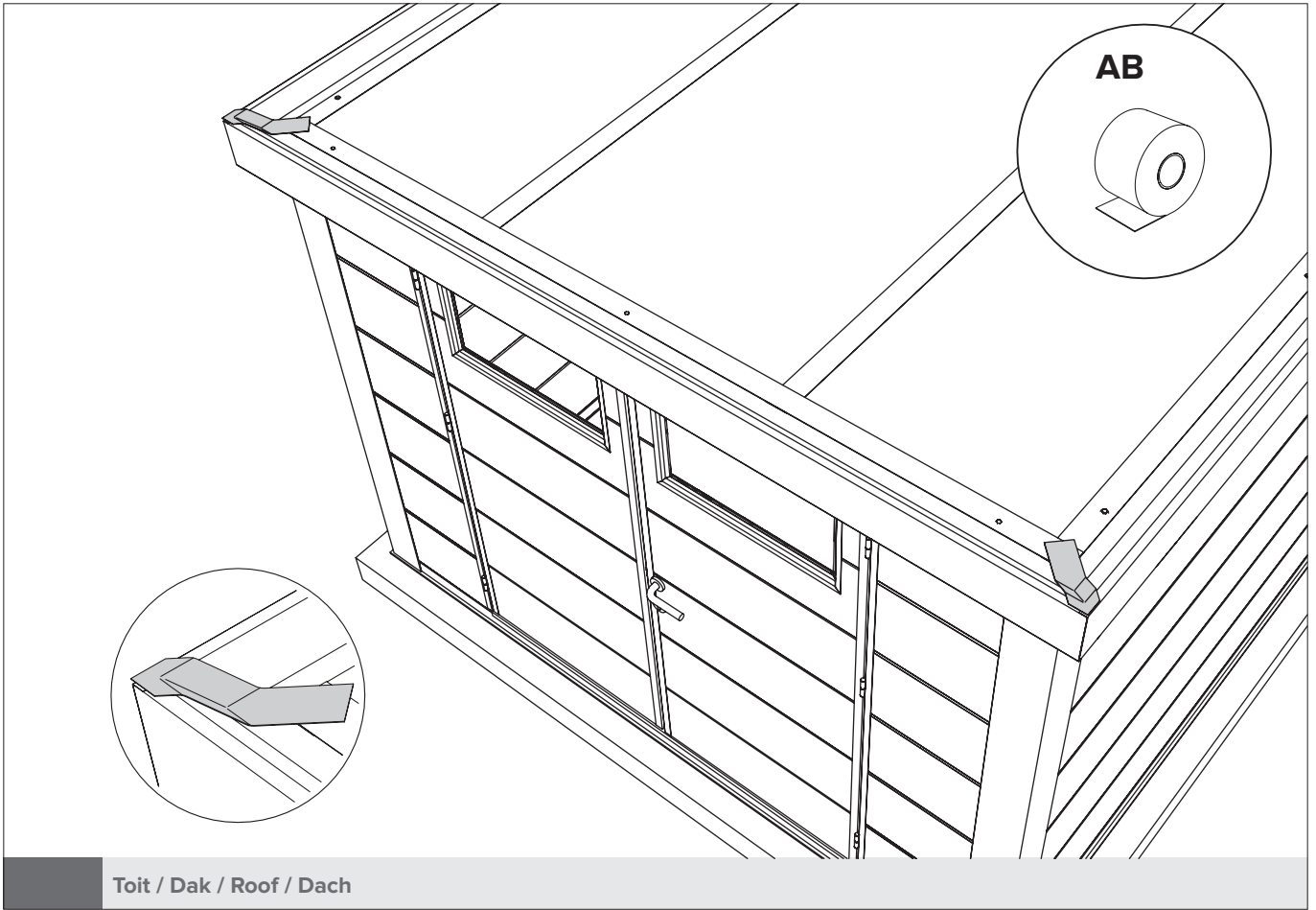

Toit / Dak / Roof / Dach

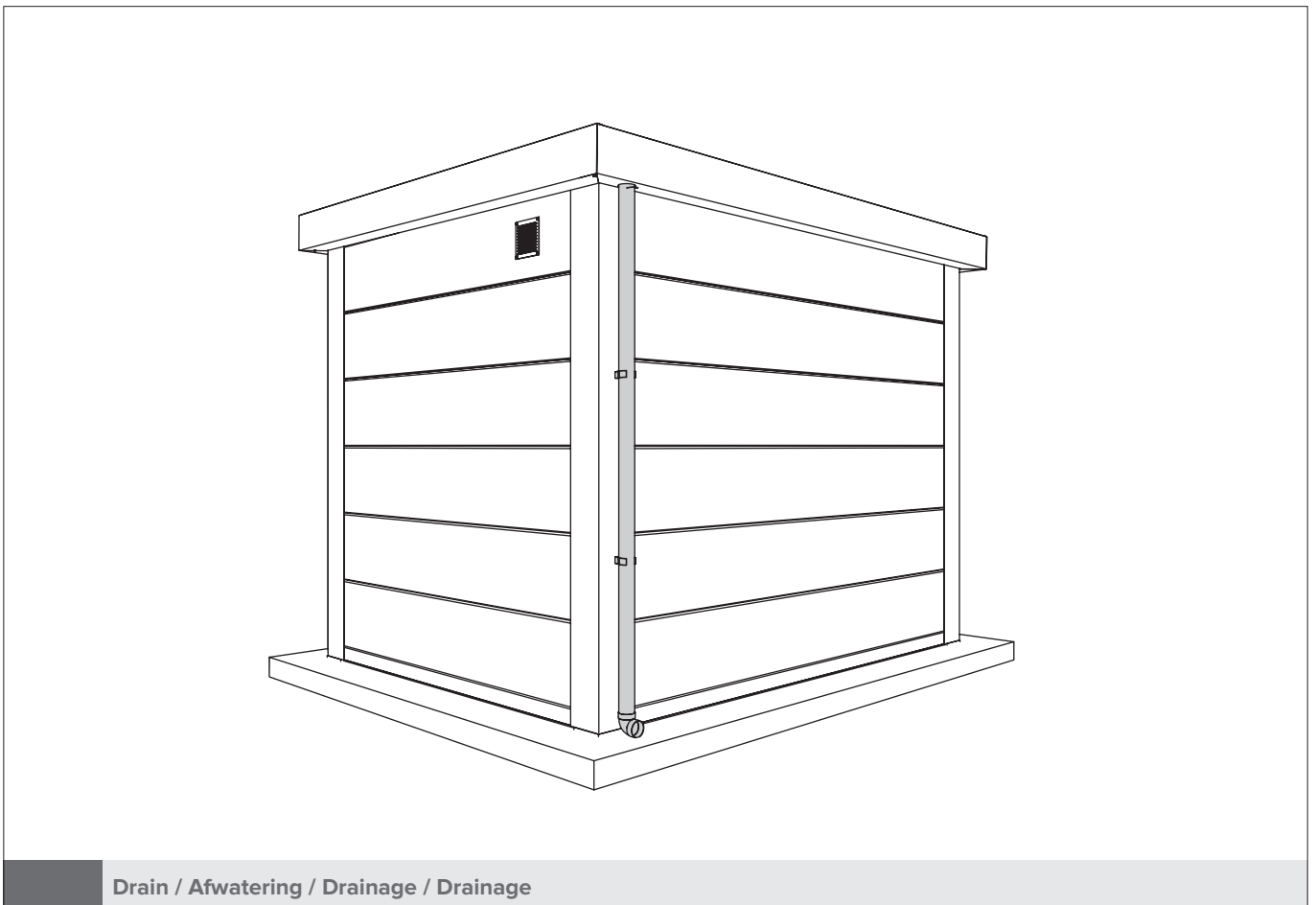

Drain / Afwatering / Drainage / Drainage

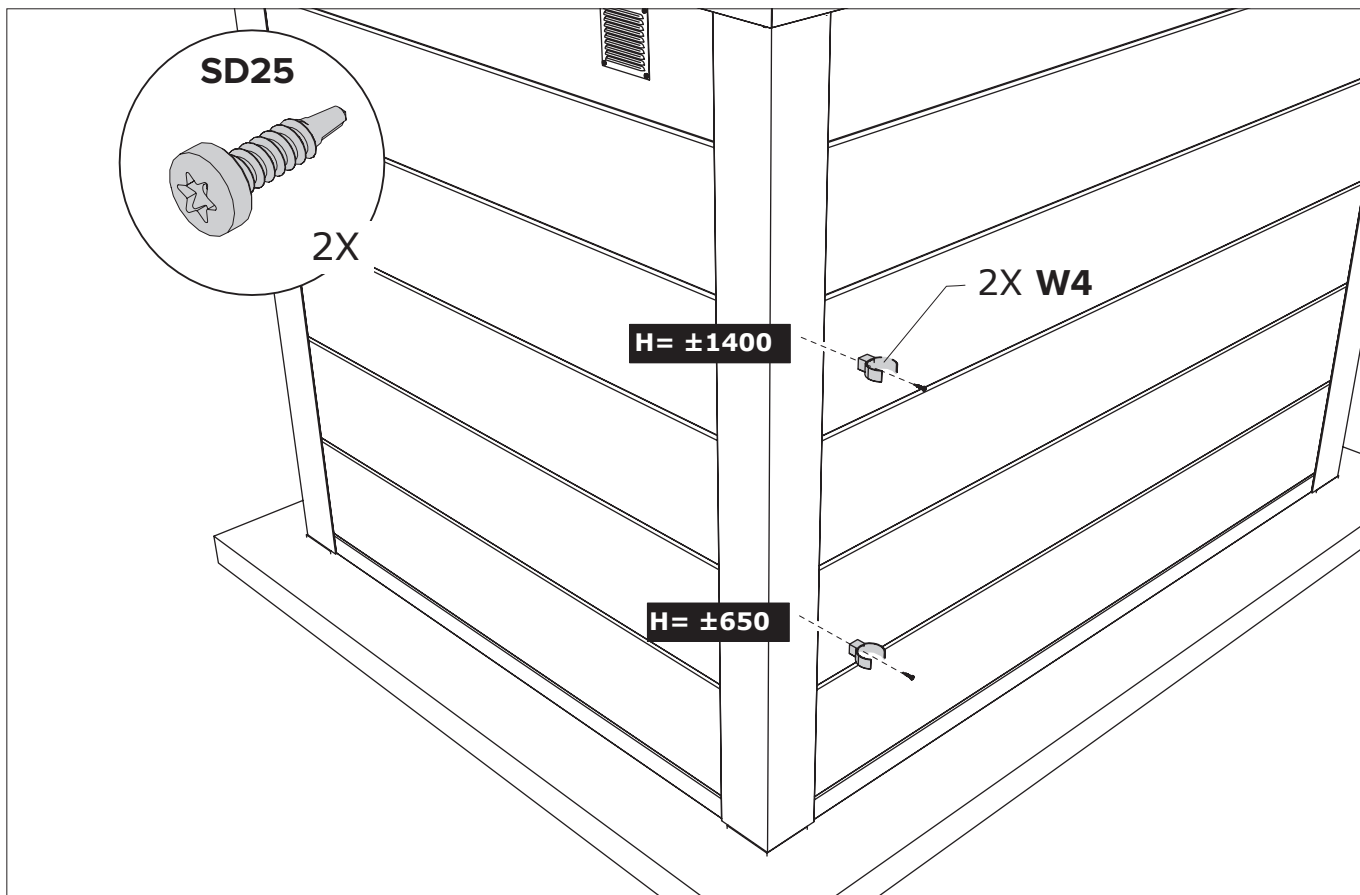

Drain / Afwatering / Drainage / Drainage

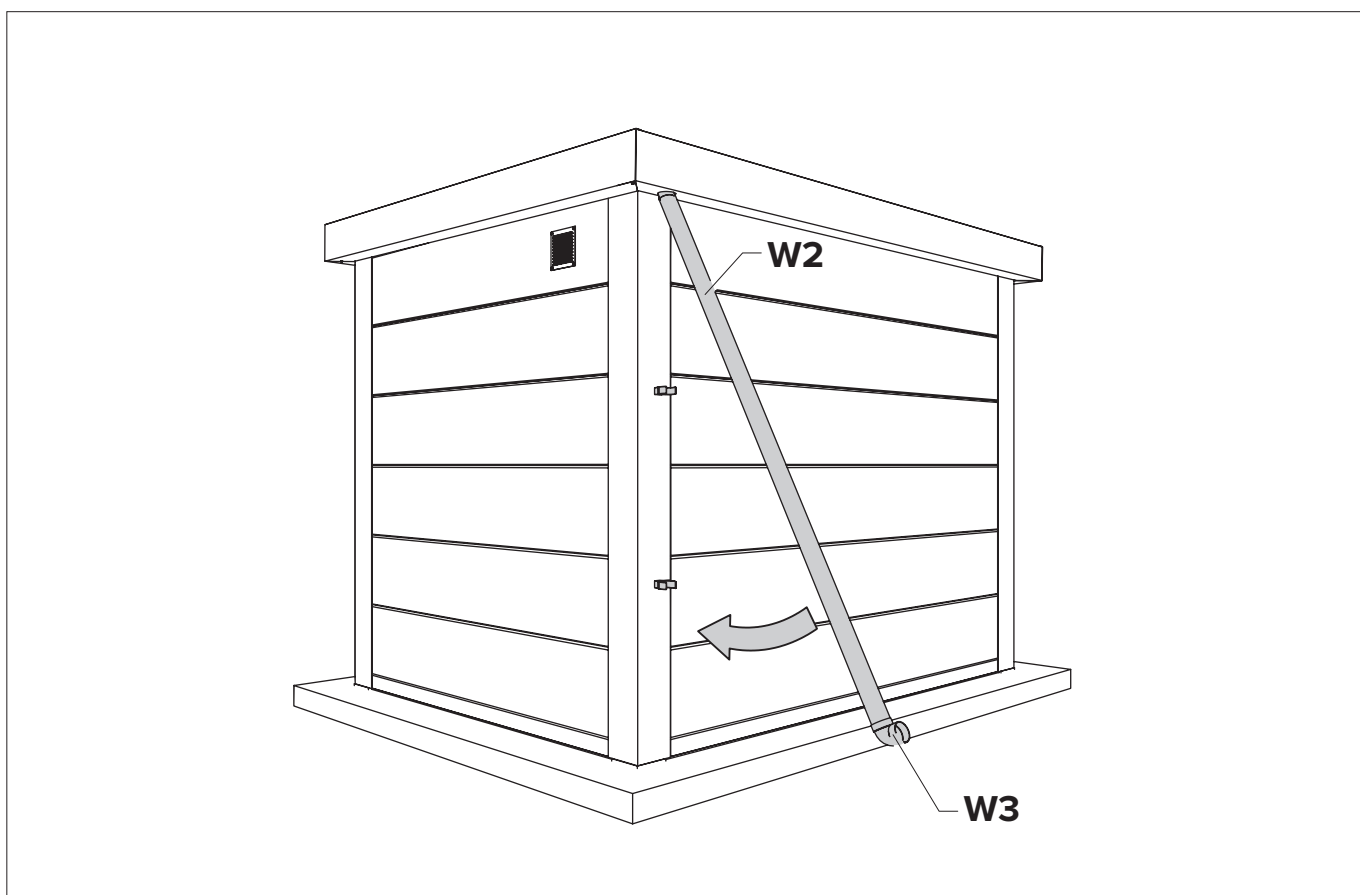

Drain / Afwatering / Drainage / Drainage

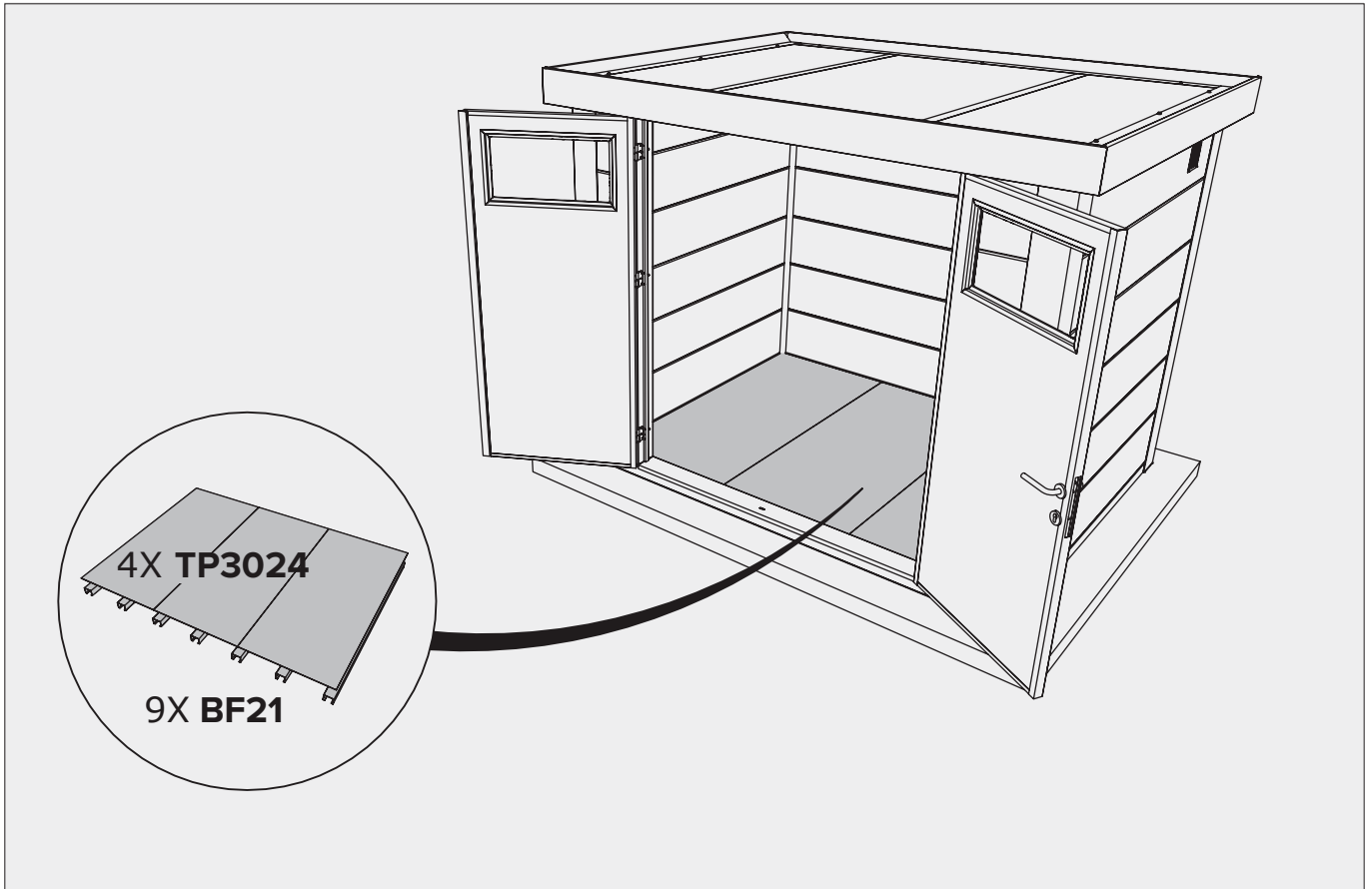

Sol / Vloer / Floor / Boden

Option / Optie / Option / Option

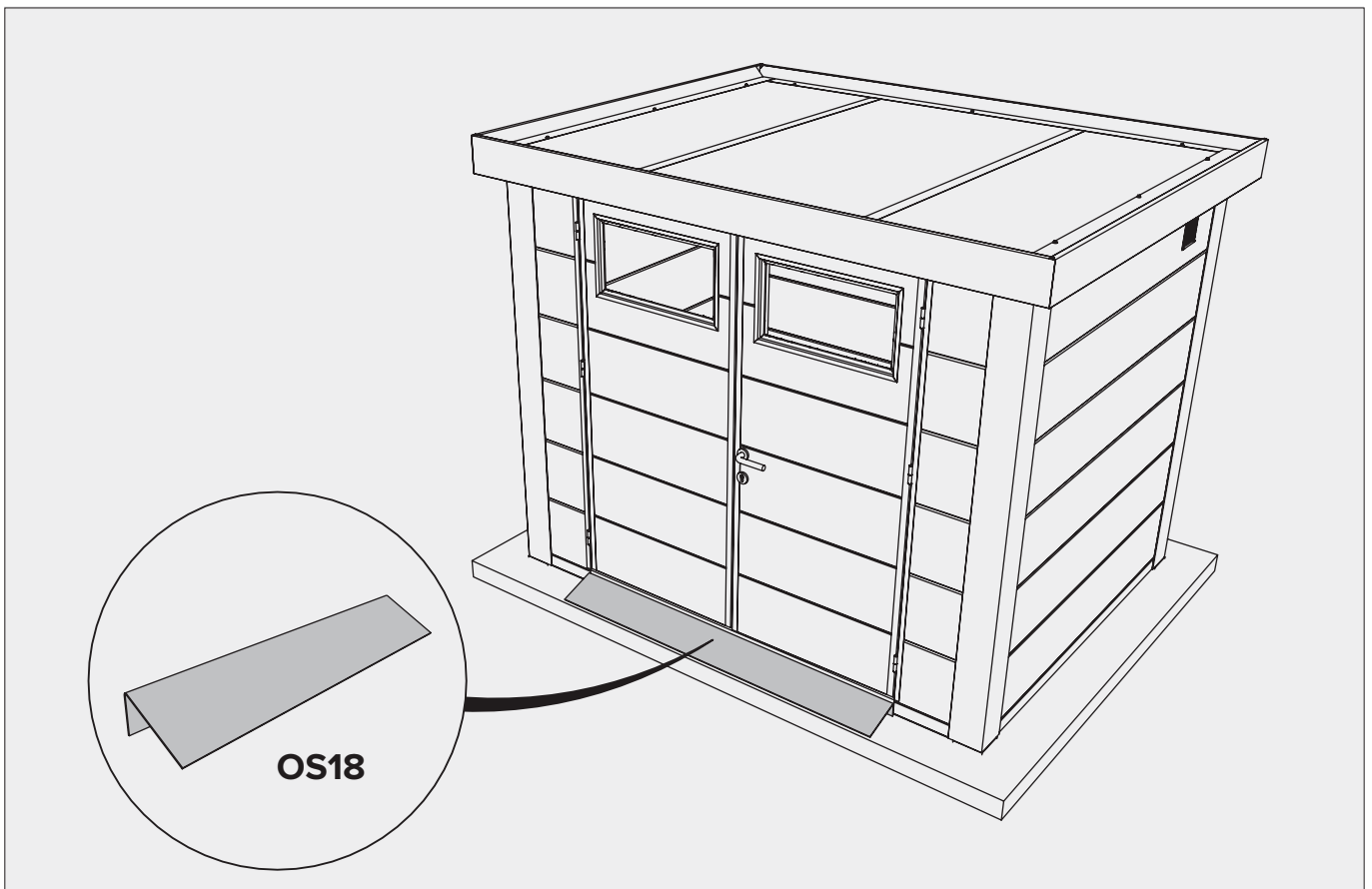

Rampe / Oprijplaat / Ramp / Rampe

Option / Optie / Option / Option

# Serviceleitfaden

## Wir legen großen Wert auf die Qualität unserer Produkte.

**Sollte es dennoch zu einer Beanstandung kommen, beachten Sie bitte folgende Hinweise:**

### Anlieferung

Sollten Sie bei der Anlieferung erkennbare Beschädigungen feststellen, halten Sie diese bitte per Fotonachweis fest und lassen sich diese zwingend von dem Anlieferungsfahrer auf dem Frachtbrief/Lieferschein dokumentieren. Kommt erst beim Öffnen des Paketes beschädigte Ware zum Vorschein, erstellen Sie bitte ebenfalls einen Fotonachweis. Die Fotonachweise fügen Sie bitte der Meldung Ihrer Beanstandung bei.

### Meldung Ihrer Beanstandung

Reichen Sie Ihre Beanstandung zwingend über unser digitales Beanstandungsformular ein. Dieses finden Sie im Bereich Service auf unserer Webseite unter <https://www.finnhaus-wolff.de/service/garantie-service>.

### Folgende Kriterien werden dort abgefragt:

- Auftragsnummer, Lieferscheinnummer oder Rechnungsnummer von Finnhaus Wolff
- Hauskontrollnummer – zu finden an der Verpackung und /oder in den Unterlagen, die dem Paket beiliegen. Anhand dieser Nummer ist uns eine eindeutige Zuordnung möglich.
- Teileliste – bitte markieren Sie die Positionen, die dem defekten / fehlenden Teil des Artikels entspricht. Bitte geben Sie dort auch die Stückzahl der benötigten Teile an.

Fügen Sie diese kommentierte Teileliste sowie die Hauskontrollnummer Ihrer Beanstandung hinzu. Unser Service-Team kümmert sich umgehend um Ihr Anliegen.

### Sie haben noch Fragen zum Einreichen Ihrer Beanstandung oder eine Frage zu Ihrem Finnhaus-Produkt?

Häufig gestellte Fragen sowie umfangreiche Informationen zum Umgang mit einer Beanstandung finden Sie im Helpcenter auf unserer Webseite unter <https://support.finnhaus.de/hc/de>.

**Herzlichen Dank für Ihre Unterstützung!**